

DIRECT-CURRENT CIRCUITS

- 26.1. IDENTIFY:** The newly-formed wire is a combination of series and parallel resistors.
SET UP: Each of the three linear segments has resistance $R/3$. The circle is two $R/6$ resistors in parallel.
EXECUTE: The resistance of the circle is $R/12$ since it consists of two $R/6$ resistors in parallel. The equivalent resistance is two $R/3$ resistors in series with an $R/6$ resistor, giving $R_{\text{equiv}} = R/3 + R/3 + R/12 = 3R/4$.
EVALUATE: The equivalent resistance of the original wire has been reduced because the circle's resistance is less than it was as a linear wire.
- 26.2. IDENTIFY:** It may appear that the meter measures X directly. But note that X is in parallel with three other resistors, so the meter measures the equivalent parallel resistance between ab .
SET UP: We use the formula for resistors in parallel.
EXECUTE: $1/(2.00 \Omega) = 1/X + 1/(15.0 \Omega) + 1/(5.0 \Omega) + 1/(10.0 \Omega)$, so $X = 7.5 \Omega$.
EVALUATE: X is *greater* than the equivalent parallel resistance of 2.00Ω .
- 26.3. (a) IDENTIFY:** Suppose we have two resistors in parallel, with $R_1 < R_2$.
SET UP: The equivalent resistance is $\frac{1}{R_{\text{eq}}} = \frac{1}{R_1} + \frac{1}{R_2}$
EXECUTE: It is always true that $\frac{1}{R_1} + \frac{1}{R_2} > \frac{1}{R_1}$. Therefore $\frac{1}{R_{\text{eq}}} > \frac{1}{R_1}$ and $R_{\text{eq}} < R_1$.
EVALUATE: The equivalent resistance is always less than that of the smallest resistor.
(b) IDENTIFY: Suppose we have N resistors in parallel, with $R_1 < R_2 < \dots < R_N$.
SET UP: The equivalent resistance is $\frac{1}{R_{\text{eq}}} = \frac{1}{R_1} + \frac{1}{R_2} + \dots + \frac{1}{R_N}$
EXECUTE: It is always true that $\frac{1}{R_1} + \frac{1}{R_2} + \dots + \frac{1}{R_N} > \frac{1}{R_1}$. Therefore $\frac{1}{R_{\text{eq}}} > \frac{1}{R_1}$ and $R_{\text{eq}} < R_1$.
EVALUATE: The equivalent resistance is always less than that of the smallest resistor.
- 26.4. IDENTIFY:** For resistors in parallel the voltages are the same and equal to the voltage across the equivalent resistance.
SET UP: $V = IR$. $\frac{1}{R_{\text{eq}}} = \frac{1}{R_1} + \frac{1}{R_2}$.
EXECUTE: (a) $R_{\text{eq}} = \left(\frac{1}{32 \Omega} + \frac{1}{20 \Omega} \right)^{-1} = 12.3 \Omega$.
 (b) $I = \frac{V}{R_{\text{eq}}} = \frac{240 \text{ V}}{12.3 \Omega} = 19.5 \text{ A}$.
 (c) $I_{32\Omega} = \frac{V}{R} = \frac{240 \text{ V}}{32 \Omega} = 7.5 \text{ A}$; $I_{20\Omega} = \frac{V}{R} = \frac{240 \text{ V}}{20 \Omega} = 12 \text{ A}$.
EVALUATE: More current flows through the resistor that has the smaller R .
- 26.5. IDENTIFY:** The equivalent resistance will vary for the different connections because the series-parallel combinations vary, and hence the current will vary.
SET UP: First calculate the equivalent resistance using the series-parallel formulas, then use Ohm's law ($V = RI$) to find the current.
EXECUTE: (a) $1/R = 1/(15.0 \Omega) + 1/(30.0 \Omega)$ gives $R = 10.0 \Omega$. $I = V/R = (35.0 \text{ V})/(10.0 \Omega) = 3.50 \text{ A}$.
 (b) $1/R = 1/(10.0 \Omega) + 1/(35.0 \Omega)$ gives $R = 7.78 \Omega$. $I = (35.0 \text{ V})/(7.78 \Omega) = 4.50 \text{ A}$
 (c) $1/R = 1/(20.0 \Omega) + 1/(25.0 \Omega)$ gives $R = 11.11 \Omega$, so $I = (35.0 \text{ V})/(11.11 \Omega) = 3.15 \text{ A}$.

(d) From part (b), the resistance of the triangle alone is 7.78Ω . Adding the $3.00\text{-}\Omega$ internal resistance of the battery gives an equivalent resistance for the circuit of 10.78Ω . Therefore the current is $I = (35.0 \text{ V})/(10.78 \Omega) = 3.25 \text{ A}$

EVALUATE: It makes a big difference how the triangle is connected to the battery.

- 26.6. IDENTIFY:** The potential drop is the same across the resistors in parallel, and the current into the parallel combination is the same as the current through the $45.0\text{-}\Omega$ resistor.

(a) **SET UP:** Apply Ohm's law in the parallel branch to find the current through the $45.0\text{-}\Omega$ resistor. Then apply Ohm's law to the $45.0\text{-}\Omega$ resistor to find the potential drop across it.

EXECUTE: The potential drop across the $25.0\text{-}\Omega$ resistor is $V_{25} = (25.0 \Omega)(1.25 \text{ A}) = 31.25 \text{ V}$. The potential drop across each of the parallel branches is 31.25 V . For the $15.0\text{-}\Omega$ resistor: $I_{15} = (31.25 \text{ V})/(15.0 \Omega) = 2.083 \text{ A}$. The resistance of the $10.0\text{-}\Omega + 15.0 \Omega$ combination is 25.0Ω , so the current through it must be the same as the current through the upper 25.0Ω resistor: $I_{10+15} = 1.25 \text{ A}$. The sum of currents in the parallel branch will be the current through the $45.0\text{-}\Omega$ resistor.

$$I_{\text{Total}} = 1.25 \text{ A} + 2.083 \text{ A} + 1.25 \text{ A} = 4.58 \text{ A}$$

Apply Ohm's law to the 45.0Ω resistor: $V_{45} = (4.58 \text{ A})(45.0 \Omega) = 206 \text{ V}$

(b) **SET UP:** First find the equivalent resistance of the circuit and then apply Ohm's law to it.

EXECUTE: The resistance of the parallel branch is $1/R = 1/(25.0 \Omega) + 1/(15.0 \Omega) + 1/(25.0 \Omega)$, so $R = 6.82 \Omega$. The equivalent resistance of the circuit is $6.82 \Omega + 45.0 \Omega + 35.00 \Omega = 86.82 \Omega$. Ohm's law gives $V_{\text{Bat}} = (86.82 \Omega)(4.58 \text{ A}) = 398 \text{ V}$.

EVALUATE: The emf of the battery is the sum of the potential drops across each of the three segments (parallel branch and two series resistors).

- 26.7. IDENTIFY:** First do as much series-parallel reduction as possible.

SET UP: The $45.0\text{-}\Omega$ and $15.0\text{-}\Omega$ resistors are in parallel, so first reduce them to a single equivalent resistance. Then find the equivalent series resistance of the circuit.

EXECUTE: $1/R_p = 1/(45.0 \Omega) + 1/(15.0 \Omega)$ and $R_p = 11.25 \Omega$. The total equivalent resistance is $18.0 \Omega + 11.25 \Omega + 3.26 \Omega = 32.5 \Omega$. Ohm's law gives $I = (25.0 \text{ V})/(32.5 \Omega) = 0.769 \text{ A}$.

EVALUATE: The circuit appears complicated until we realize that the $45.0\text{-}\Omega$ and $15.0\text{-}\Omega$ resistors are in parallel.

- 26.8. IDENTIFY:** Eq.(26.2) gives the equivalent resistance of the three resistors in parallel. For resistors in parallel, the voltages are the same and the currents add.

(a) **SET UP:** The circuit is sketched in Figure 26.8a.

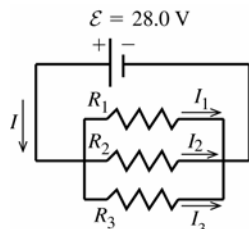

Figure 26.8a

EXECUTE: parallel

$$\frac{1}{R_{\text{eq}}} = \frac{1}{R_1} + \frac{1}{R_2} + \frac{1}{R_3}$$

$$\frac{1}{R_{\text{eq}}} = \frac{1}{1.60 \Omega} + \frac{1}{2.40 \Omega} + \frac{1}{4.80 \Omega}$$

$$R_{\text{eq}} = 0.800 \Omega$$

(b) For resistors in parallel the voltage is the same across each and equal to the applied voltage;

$$V_1 = V_2 = V_3 = \mathcal{E} = 28.0 \text{ V}$$

$$V = IR \text{ so } I_1 = \frac{V_1}{R_1} = \frac{28.0 \text{ V}}{1.60 \Omega} = 17.5 \text{ A}$$

$$I_2 = \frac{V_2}{R_2} = \frac{28.0 \text{ V}}{2.40 \Omega} = 11.7 \text{ A} \text{ and } I_3 = \frac{V_3}{R_3} = \frac{28.0 \text{ V}}{4.8 \Omega} = 5.8 \text{ A}$$

(c) The currents through the resistors add to give the current through the battery:

$$I = I_1 + I_2 + I_3 = 17.5 \text{ A} + 11.7 \text{ A} + 5.8 \text{ A} = 35.0 \text{ A}$$

EVALUATE: Alternatively, we can use the equivalent resistance R_{eq} as shown in Figure 26.8b.

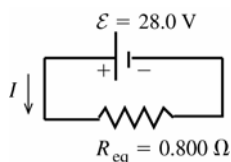

Figure 26.8b

$$\mathcal{E} - IR_{\text{eq}} = 0$$

$$I = \frac{\mathcal{E}}{R_{\text{eq}}} = \frac{28.0 \text{ V}}{0.800 \Omega} = 35.0 \text{ A},$$

which checks

(d) As shown in part (b), the voltage across each resistor is 28.0 V .

(e) **IDENTIFY and SET UP:** We can use any of the three expressions for P : $P = VI = I^2R = V^2/R$. They will all give the same results, if we keep enough significant figures in intermediate calculations.

EXECUTE: Using $P = V^2/R$, $P_1 = V_1^2/R_1 = \frac{(28.0 \text{ V})^2}{1.60 \Omega} = 490 \text{ W}$, $P_2 = V_2^2/R_2 = \frac{(28.0 \text{ V})^2}{2.40 \Omega} = 327 \text{ W}$, and

$$P_3 = V_3^2/R_3 = \frac{(28.0 \text{ V})^2}{4.80 \Omega} = 163 \text{ W}$$

EVALUATE: The total power dissipated is $P_{\text{out}} = P_1 + P_2 + P_3 = 980 \text{ W}$. This is the same as the power $P_{\text{in}} = \mathcal{E}I = (2.80 \text{ V})(35.0 \text{ A}) = 980 \text{ W}$ delivered by the battery.

(f) $P = V^2/R$. The resistors in parallel each have the same voltage, so the power P is largest for the one with the least resistance.

26.9. IDENTIFY: For a series network, the current is the same in each resistor and the sum of voltages for each resistor equals the battery voltage. The equivalent resistance is $R_{\text{eq}} = R_1 + R_2 + R_3$. $P = I^2R$.

SET UP: Let $R_1 = 1.60 \Omega$, $R_2 = 2.40 \Omega$, $R_3 = 4.80 \Omega$.

EXECUTE: (a) $R_{\text{eq}} = 1.60 \Omega + 2.40 \Omega + 4.80 \Omega = 8.80 \Omega$

(b) $I = \frac{V}{R_{\text{eq}}} = \frac{28.0 \text{ V}}{8.80 \Omega} = 3.18 \text{ A}$

(c) $I = 3.18 \text{ A}$, the same as for each resistor.

(d) $V_1 = IR_1 = (3.18 \text{ A})(1.60 \Omega) = 5.09 \text{ V}$. $V_2 = IR_2 = (3.18 \text{ A})(2.40 \Omega) = 7.63 \text{ V}$.

$V_3 = IR_3 = (3.18 \text{ A})(4.80 \Omega) = 15.3 \text{ V}$. Note that $V_1 + V_2 + V_3 = 28.0 \text{ V}$.

(e) $P_1 = I^2R_1 = (3.18 \text{ A})^2(1.60 \Omega) = 16.2 \text{ W}$. $P_2 = I^2R_2 = (3.18 \text{ A})^2(2.40 \Omega) = 24.3 \text{ W}$.

$P_3 = I^2R_3 = (3.18 \text{ A})^2(4.80 \Omega) = 48.5 \text{ W}$.

(f) Since $P = I^2R$ and the current is the same for each resistor, the resistor with the greatest R dissipates the greatest power.

EVALUATE: When resistors are connected in parallel, the resistor with the smallest R dissipates the greatest power.

26.10. (a) IDENTIFY: The current, and hence the power, depends on the potential difference across the resistor.

SET UP: $P = V^2/R$

EXECUTE: (a) $V = \sqrt{PR} = \sqrt{(5.0 \text{ W})(15,000 \Omega)} = 274 \text{ V}$

(b) $P = V^2/R = (120 \text{ V})^2/(9,000 \Omega) = 1.6 \text{ W}$

SET UP: (c) If the larger resistor generates 2.00 W, the smaller one will generate less and hence will be safe.

Therefore the maximum power in the larger resistor must be 2.00 W. Use $P = I^2R$ to find the maximum current through the series combination and use Ohm's law to find the potential difference across the combination.

EXECUTE: $P = I^2R$ gives $I = P/R = (2.00 \text{ W})/(150 \Omega) = 0.0133 \text{ A}$. The same current flows through both resistors, and their equivalent resistance is 250 Ω . Ohm's law gives $V = IR = (0.0133 \text{ A})(250 \Omega) = 3.33 \text{ V}$.

Therefore $P_{150} = 2.00 \text{ W}$ and $P_{100} = I^2R = (0.0133 \text{ A})^2(100 \Omega) = 0.0177 \text{ W}$.

EVALUATE: If the resistors in a series combination all have the same power rating, it is the *largest* resistance that limits the amount of current.

26.11. IDENTIFY: For resistors in parallel, the voltages are the same and the currents add. $\frac{1}{R_{\text{eq}}} = \frac{1}{R_1} + \frac{1}{R_2}$ so $R_{\text{eq}} = \frac{R_1R_2}{R_1 + R_2}$,

For resistors in series, the currents are the same and the voltages add. $R_{\text{eq}} = R_1 + R_2$.

SET UP: The rules for combining resistors in series and parallel lead to the sequences of equivalent circuits shown in Figure 26.11.

EXECUTE: $R_{\text{eq}} = 5.00 \Omega$. In Figure 26.11c, $I = \frac{60.0 \text{ V}}{5.00 \Omega} = 12.0 \text{ A}$. This is the current through each of the

resistors in Figure 26.11b. $V_{12} = IR_{12} = (12.0 \text{ A})(2.00 \Omega) = 24.0 \text{ V}$. $V_{34} = IR_{34} = (12.0 \text{ A})(3.00 \Omega) = 36.0 \text{ V}$. Note

that $V_{12} + V_{34} = 60.0 \text{ V}$. V_{12} is the voltage across R_1 and across R_2 , so $I_1 = \frac{V_{12}}{R_1} = \frac{24.0 \text{ V}}{3.00 \Omega} = 8.00 \text{ A}$ and

$I_2 = \frac{V_{12}}{R_2} = \frac{24.0 \text{ V}}{6.00 \Omega} = 4.00 \text{ A}$. V_{34} is the voltage across R_3 and across R_4 , so $I_3 = \frac{V_{34}}{R_3} = \frac{36.0 \text{ V}}{12.0 \Omega} = 3.00 \text{ A}$ and

$I_4 = \frac{V_{34}}{R_4} = \frac{36.0 \text{ V}}{4.00 \Omega} = 9.00 \text{ A}$.

EVALUATE: Note that $I_1 + I_2 = I_3 + I_4$.

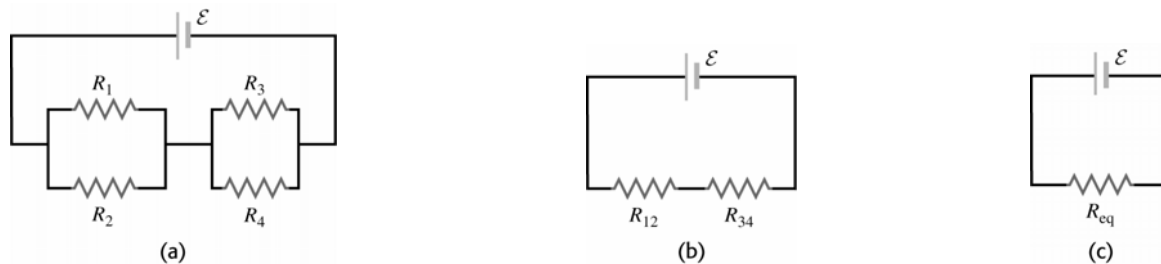

Figure 26.11

26.12. IDENTIFY: Replace the series combinations of resistors by their equivalents. In the resulting parallel network the battery voltage is the voltage across each resistor.

SET UP: The circuit is sketched in Figure 26.12a.

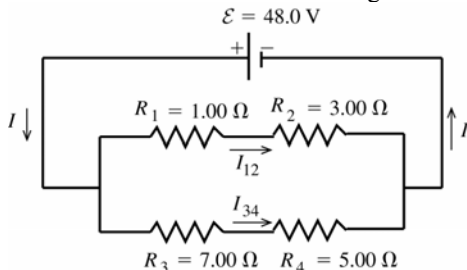

Figure 26.12a

EXECUTE: R_1 and R_2 in series have an equivalent resistance of $R_{12} = R_1 + R_2 = 4.00 \Omega$

R_3 and R_4 in series have an equivalent resistance of $R_{34} = R_3 + R_4 = 12.0 \Omega$

The circuit is equivalent to the circuit sketched in Figure 26.12b.

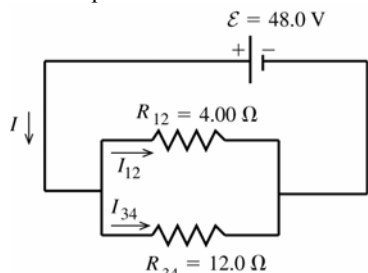

Figure 26.12b

R_{12} and R_{34} in parallel are equivalent to

$$R_{\text{eq}} \text{ given by } \frac{1}{R_{\text{eq}}} = \frac{1}{R_{12}} + \frac{1}{R_{34}} = \frac{R_{12} + R_{34}}{R_{12}R_{34}}$$

$$R_{\text{eq}} = \frac{R_{12}R_{34}}{R_{12} + R_{34}}$$

$$R_{\text{eq}} = \frac{(4.00 \Omega)(12.0 \Omega)}{4.00 \Omega + 12.0 \Omega} = 3.00 \Omega$$

The voltage across each branch of the parallel combination is \mathcal{E} , so $\mathcal{E} - I_{12}R_{12} = 0$.

$$I_{12} = \frac{\mathcal{E}}{R_{12}} = \frac{48.0 \text{ V}}{4.00 \Omega} = 12.0 \text{ A}$$

$$\mathcal{E} - I_{34}R_{34} = 0 \text{ so } I_{34} = \frac{\mathcal{E}}{R_{34}} = \frac{48.0 \text{ V}}{12.0 \Omega} = 4.0 \text{ A}$$

The current is 12.0 A through the 1.00 Ω and 3.00 Ω resistors, and it is 4.0 A through the 7.00 Ω and 5.00 Ω resistors.

EVALUATE: The current through the battery is $I = I_{12} + I_{34} = 12.0 \text{ A} + 4.0 \text{ A} = 16.0 \text{ A}$, and this is equal to

$$\mathcal{E}/R_{\text{eq}} = 48.0 \text{ V}/3.00 \Omega = 16.0 \text{ A}.$$

26.13. IDENTIFY: In both circuits, with and without R_4 , replace series and parallel combinations of resistors by their equivalents. Calculate the currents and voltages in the equivalent circuit and infer from this the currents and voltages in the original circuit. Use $P = I^2R$ to calculate the power dissipated in each bulb.

(a) SET UP: The circuit is sketched in Figure 26.13a.

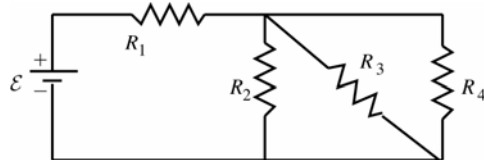

Figure 26.13a

EXECUTE: R_2 , R_3 , and R_4 are in parallel, so their equivalent resistance

$$R_{\text{eq}} \text{ is given by } \frac{1}{R_{\text{eq}}} = \frac{1}{R_2} + \frac{1}{R_3} + \frac{1}{R_4}$$

$$\frac{1}{R_{\text{eq}}} = \frac{3}{4.50 \Omega} \text{ and } R_{\text{eq}} = 1.50 \Omega.$$

The equivalent circuit is drawn in Figure 26.13b.

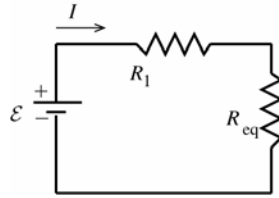

Figure 26.13b

$$\mathcal{E} - I(R_1 + R_{\text{eq}}) = 0$$

$$I = \frac{\mathcal{E}}{R_1 + R_{\text{eq}}}$$

$$I = \frac{9.00 \text{ V}}{4.50 \Omega + 1.50 \Omega} = 1.50 \text{ A} \text{ and } I_1 = 1.50 \text{ A}$$

$$\text{Then } V_1 = I_1 R_1 = (1.50 \text{ A})(4.50 \Omega) = 6.75 \text{ V}$$

$$I_{\text{eq}} = 1.50 \text{ A}, V_{\text{eq}} = I_{\text{eq}} R_{\text{eq}} = (1.50 \text{ A})(1.50 \Omega) = 2.25 \text{ V}$$

For resistors in parallel the voltages are equal and are the same as the voltage across the equivalent resistor, so

$$V_2 = V_3 = V_4 = 2.25 \text{ V}.$$

$$I_2 = \frac{V_2}{R_2} = \frac{2.25 \text{ V}}{4.50 \Omega} = 0.500 \text{ A}, I_3 = \frac{V_3}{R_3} = 0.500 \text{ A}, I_4 = \frac{V_4}{R_4} = 0.500 \text{ A}$$

EVALUATE: Note that $I_2 + I_3 + I_4 = 1.50 \text{ A}$, which is I_{eq} . For resistors in parallel the currents add and their sum is the current through the equivalent resistor.

(b) SET UP: $P = I^2 R$

$$\text{EXECUTE: } P_1 = (1.50 \text{ A})^2 (4.50 \Omega) = 10.1 \text{ W}$$

$$P_2 = P_3 = P_4 = (0.500 \text{ A})^2 (4.50 \Omega) = 1.125 \text{ W}, \text{ which rounds to } 1.12 \text{ W. } R_1 \text{ glows brightest.}$$

EVALUATE: Note that $P_2 + P_3 + P_4 = 3.37 \text{ W}$. This equals $P_{\text{eq}} = I_{\text{eq}}^2 R_{\text{eq}} = (1.50 \text{ A})^2 (1.50 \Omega) = 3.37 \text{ W}$, the power dissipated in the equivalent resistor.

(c) SET UP: With R_4 removed the circuit becomes the circuit in Figure 26.13c.

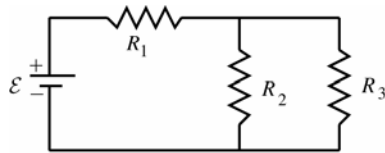

Figure 26.13c

EXECUTE: R_2 and R_3 are in parallel and their equivalent resistance R_{eq} is given by

$$\frac{1}{R_{\text{eq}}} = \frac{1}{R_2} + \frac{1}{R_3} = \frac{2}{4.50 \Omega} \text{ and } R_{\text{eq}} = 2.25 \Omega$$

The equivalent circuit is shown in Figure 26.13d.

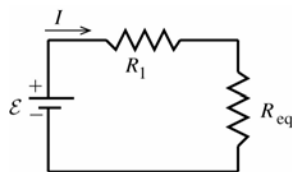

Figure 26.13d

$$\mathcal{E} - I(R_1 + R_{\text{eq}}) = 0$$

$$I = \frac{\mathcal{E}}{R_1 + R_{\text{eq}}}$$

$$I = \frac{9.00 \text{ V}}{4.50 \Omega + 2.25 \Omega} = 1.333 \text{ A}$$

$$I_1 = 1.33 \text{ A}, V_1 = I_1 R_1 = (1.333 \text{ A})(4.50 \Omega) = 6.00 \text{ V}$$

$$I_{\text{eq}} = 1.33 \text{ A}, V_{\text{eq}} = I_{\text{eq}} R_{\text{eq}} = (1.333 \text{ A})(2.25 \Omega) = 3.00 \text{ V} \text{ and } V_2 = V_3 = 3.00 \text{ V}.$$

$$I_2 = \frac{V_2}{R_2} = \frac{3.00 \text{ V}}{4.50 \Omega} = 0.667 \text{ A}, I_3 = \frac{V_3}{R_3} = 0.667 \text{ A}$$

(d) SET UP: $P = I^2 R$

$$\text{EXECUTE: } P_1 = (1.333 \text{ A})^2 (4.50 \Omega) = 8.00 \text{ W}$$

$$P_2 = P_3 = (0.667 \text{ A})^2 (4.50 \Omega) = 2.00 \text{ W}.$$

(e) EVALUATE: When R_4 is removed, P_1 decreases and P_2 and P_3 increase. Bulb R_1 glows less brightly and bulbs R_2 and R_3 glow more brightly. When R_4 is removed the equivalent resistance of the circuit increases and the current through R_1 decreases. But in the parallel combination this current divides into two equal currents rather than three, so the currents through R_2 and R_3 increase. Can also see this by noting that with R_4 removed and less current through R_1 the voltage drop across R_1 is less so the voltage drop across R_2 and across R_3 must become larger.

26.14. IDENTIFY: Apply Ohm's law to each resistor.

SET UP: For resistors in parallel the voltages are the same and the currents add. For resistors in series the currents are the same and the voltages add.

EXECUTE: From Ohm's law, the voltage drop across the $6.00\ \Omega$ resistor is $V = IR = (4.00\ \text{A})(6.00\ \Omega) = 24.0\ \text{V}$. The voltage drop across the $8.00\ \Omega$ resistor is the same, since these two resistors are wired in parallel. The current through the $8.00\ \Omega$ resistor is then $I = V/R = 24.0\ \text{V}/8.00\ \Omega = 3.00\ \text{A}$. The current through the $25.0\ \Omega$ resistor is the sum of these two currents: $7.00\ \text{A}$. The voltage drop across the $25.0\ \Omega$ resistor is $V = IR = (7.00\ \text{A})(25.0\ \Omega) = 175\ \text{V}$, and total voltage drop across the top branch of the circuit is $175\ \text{V} + 24.0\ \text{V} = 199\ \text{V}$, which is also the voltage drop across the $20.0\ \Omega$ resistor. The current through the $20.0\ \Omega$ resistor is then $I = V/R = 199\ \text{V}/20\ \Omega = 9.95\ \text{A}$.

EVALUATE: The total current through the battery is $7.00\ \text{A} + 9.95\ \text{A} = 16.95\ \text{A}$. Note that we did not need to calculate the emf of the battery.

26.15. IDENTIFY: Apply Ohm's law to each resistor.

SET UP: For resistors in parallel the voltages are the same and the currents add. For resistors in series the currents are the same and the voltages add.

EXECUTE: The current through $2.00\text{-}\Omega$ resistor is $6.00\ \text{A}$. Current through $1.00\text{-}\Omega$ resistor also is $6.00\ \text{A}$ and the voltage is $6.00\ \text{V}$. Voltage across the $6.00\text{-}\Omega$ resistor is $12.0\ \text{V} + 6.0\ \text{V} = 18.0\ \text{V}$. Current through the $6.00\text{-}\Omega$ resistor is $(18.0\ \text{V})/(6.00\ \Omega) = 3.00\ \text{A}$. The battery emf is $18.0\ \text{V}$.

EVALUATE: The current through the battery is $6.00\ \text{A} + 3.00\ \text{A} = 9.00\ \text{A}$. The equivalent resistor of the resistor network is $2.00\ \Omega$, and this equals $(18.0\ \text{V})/(9.00\ \text{A})$.

26.16. IDENTIFY: The filaments must be connected such that the current can flow through each separately, and also through both in parallel, yielding three possible current flows. The parallel situation always has less resistance than any of the individual members, so it will give the highest power output of $180\ \text{W}$, while the other two must give power outputs of $60\ \text{W}$ and $120\ \text{W}$.

SET UP: $P = V^2/R$, where R is the equivalent resistance.

EXECUTE: (a) $60\ \text{W} = \frac{V^2}{R_1}$ gives $R_1 = \frac{(120\ \text{V})^2}{60\ \text{W}} = 240\ \Omega$. $120\ \text{W} = \frac{V^2}{R_2}$ gives $R_2 = \frac{(120\ \text{V})^2}{120\ \text{W}} = 120\ \Omega$. For these

two resistors in parallel, $R_{\text{eq}} = \frac{R_1 R_2}{R_1 + R_2} = 80\ \Omega$ and $P = \frac{V^2}{R_{\text{eq}}} = \frac{(120\ \text{V})^2}{80\ \Omega} = 180\ \text{W}$, which is the desired value.

(b) If R_1 burns out, the $120\ \text{W}$ setting stays the same, the $60\ \text{W}$ setting does not work and the $180\ \text{W}$ setting goes to $120\ \text{W}$: brightnesses of zero, medium and medium.

(c) If R_2 burns out, the $60\ \text{W}$ setting stays the same, the $120\ \text{W}$ setting does not work, and the $180\ \text{W}$ setting is now $60\ \text{W}$: brightnesses of low, zero and low.

EVALUATE: Since in each case $120\ \text{V}$ is supplied to each filament network, the lowest resistance dissipates the greatest power.

26.17. IDENTIFY: For resistors in series, the voltages add and the current is the same. For resistors in parallel, the voltages are the same and the currents add. $P = I^2 R$.

(a) **SET UP:** The circuit is sketched in Figure 26.17a.

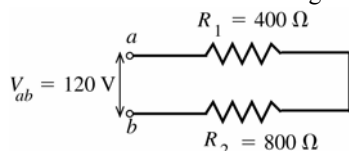

Figure 26.17a

For resistors in series the current is the same through each.

EXECUTE: $R_{\text{eq}} = R_1 + R_2 = 1200\ \Omega$. $I = \frac{V}{R_{\text{eq}}} = \frac{120\ \text{V}}{1200\ \Omega} = 0.100\ \text{A}$. This is the current drawn from the line.

(b) $P_1 = I^2 R_1 = (0.100\ \text{A})^2 (400\ \Omega) = 4.0\ \text{W}$

$P_2 = I^2 R_2 = (0.100\ \text{A})^2 (800\ \Omega) = 8.0\ \text{W}$

(c) $P_{\text{out}} = P_1 + P_2 = 12.0\ \text{W}$, the total power dissipated in both bulbs. Note that

$P_{\text{in}} = V_{ab} I = (120\ \text{V})(0.100\ \text{A}) = 12.0\ \text{W}$, the power delivered by the potential source, equals P_{out} .

(d) **SET UP:** The circuit is sketched in Figure 26.17b.

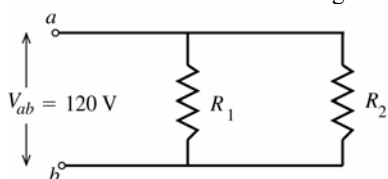

Figure 26.17b

For resistors in parallel the voltage across each resistor is the same.

EXECUTE: $I_1 = \frac{V_1}{R_1} = \frac{120 \text{ V}}{400 \Omega} = 0.300 \text{ A}$, $I_2 = \frac{V_2}{R_2} = \frac{120 \text{ V}}{800 \Omega} = 0.150 \text{ A}$

EVALUATE: Note that each current is larger than the current when the resistors are connected in series.

(e) **EXECUTE:** $P_1 = I_1^2 R_1 = (0.300 \text{ A})^2 (400 \Omega) = 36.0 \text{ W}$

$P_2 = I_2^2 R_2 = (0.150 \text{ A})^2 (800 \Omega) = 18.0 \text{ W}$

(f) $P_{\text{out}} = P_1 + P_2 = 54.0 \text{ W}$

EVALUATE: Note that the total current drawn from the line is $I = I_1 + I_2 = 0.450 \text{ A}$. The power input from the line is $P_{\text{in}} = V_{ab} I = (120 \text{ V})(0.450 \text{ A}) = 54.0 \text{ W}$, which equals the total power dissipated by the bulbs.

(g) The bulb that is dissipating the most power glows most brightly. For the series connection the currents are the same and by $P = I^2 R$ the bulb with the larger R has the larger P ; the 800Ω bulb glows more brightly. For the parallel combination the voltages are the same and by $P = V^2 / R$ the bulb with the smaller R has the larger P ; the 400Ω bulb glows more brightly.

(h) The total power output P_{out} equals $P_{\text{in}} = V_{ab} I$, so P_{out} is larger for the parallel connection where the current drawn from the line is larger (because the equivalent resistance is smaller.)

26.18. IDENTIFY: Use $P = V^2 / R$ with $V = 120 \text{ V}$ and the wattage for each bulb to calculate the resistance of each bulb. When connected in series the voltage across each bulb will not be 120 V and the power for each bulb will be different.

SET UP: For resistors in series the currents are the same and $R_{\text{eq}} = R_1 + R_2$.

EXECUTE: (a) $R_{60\text{W}} = \frac{V^2}{P} = \frac{(120 \text{ V})^2}{60 \text{ W}} = 240 \Omega$; $R_{200\text{W}} = \frac{V^2}{P} = \frac{(120 \text{ V})^2}{200 \text{ W}} = 72 \Omega$.

Therefore, $I_{60\text{W}} = I_{200\text{W}} = \frac{\mathcal{E}}{R} = \frac{240 \text{ V}}{(240 \Omega + 72 \Omega)} = 0.769 \text{ A}$.

(b) $P_{60\text{W}} = I^2 R = (0.769 \text{ A})^2 (240 \Omega) = 142 \text{ W}$; $P_{200\text{W}} = I^2 R = (0.769 \text{ A})^2 (72 \Omega) = 42.6 \text{ W}$.

(c) The 60 W bulb burns out quickly because the power it delivers (142 W) is 2.4 times its rated value.

EVALUATE: In series the largest resistance dissipates the greatest power.

26.19. IDENTIFY and SET UP: Replace series and parallel combinations of resistors by their equivalents until the circuit is reduced to a single loop. Use the loop equation to find the current through the 20.0Ω resistor. Set $P = I^2 R$ for the 20.0Ω resistor equal to the rate Q/t at which heat goes into the water and set $Q = mc\Delta T$.

EXECUTE: Replace the network by the equivalent resistor, as shown in Figure 26.19.

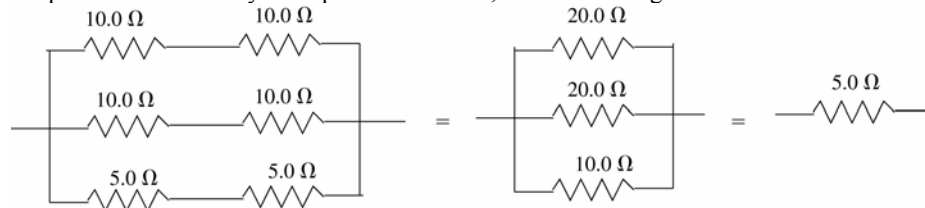

Figure 26.19

$30.0 \text{ V} - I(20.0 \Omega + 5.0 \Omega + 5.0 \Omega) = 0$; $I = 1.00 \text{ A}$

For the $20.0\text{-}\Omega$ resistor thermal energy is generated at the rate $P = I^2 R = 20.0 \text{ W}$. $Q = Pt$ and $Q = mc\Delta T$ gives

$t = \frac{mc\Delta T}{P} = \frac{(0.100 \text{ kg})(4190 \text{ J/kg} \cdot \text{K})(48.0 \text{ C}^\circ)}{20.0 \text{ W}} = 1.01 \times 10^3 \text{ s}$

EVALUATE: The battery is supplying heat at the rate $P = \mathcal{E}I = 30.0 \text{ W}$. In the series circuit, more energy is dissipated in the larger resistor (20.0Ω) than in the smaller ones (5.00Ω).

26.20. IDENTIFY: $P = I^2 R$ determines R_1 . R_1 , R_2 and the 10.0Ω resistor are all in parallel so have the same voltage. Apply the junction rule to find the current through R_2 .

SET UP: $P = I^2 R$ for a resistor and $P = \mathcal{E}I$ for an emf. The emf inputs electrical energy into the circuit and electrical energy is removed in the resistors.

EXECUTE: (a) $P_1 = I_1^2 R_1$. $20 \text{ W} = (2 \text{ A})^2 R_1$ and $R_1 = 5.00 \Omega$. R_1 and 10Ω are in parallel, so

$(10 \Omega)I_{10} = (5 \Omega)(2 \text{ A})$ and $I_{10} = 1 \text{ A}$. So $I_2 = 3.50 \text{ A} - I_1 - I_{10} = 0.50 \text{ A}$. R_1 and R_2 are in parallel, so

$(0.50 \text{ A})R_2 = (2 \text{ A})(5 \Omega)$ and $R_2 = 20.0 \Omega$.

(b) $\mathcal{E} = V_1 = (2.00 \text{ A})(5.00 \Omega) = 10.0 \text{ V}$

(c) From part (a), $I_2 = 0.500 \text{ A}$, $I_{10} = 1.00 \text{ A}$

(d) $P_1 = 20.0 \text{ W}$ (given). $P_2 = I_2^2 R_2 = (0.50 \text{ A})^2 (20 \Omega) = 5.00 \text{ W}$. $P_{10} = I_{10}^2 R_{10} = (1.0 \text{ A})^2 (10 \Omega) = 10.0 \text{ W}$. The total rate at which the resistors remove electrical energy is $P_{\text{Resist}} = 20 \text{ W} + 5 \text{ W} + 10 \text{ W} = 35.0 \text{ W}$. The total rate at which the battery inputs electrical energy is $P_{\text{Battery}} = I \mathcal{E} = (3.50 \text{ A})(10.0 \text{ V}) = 35.0 \text{ W}$. $P_{\text{Resist}} = P_{\text{Battery}}$, which agrees with conservation of energy.

EVALUATE: The three resistors are in parallel, so the voltage for each is the battery voltage, 10.0 V. The currents in the three resistors add to give the current in the battery.

26.21. IDENTIFY: Apply Kirchoff's point rule at point a to find the current through R . Apply Kirchoff's loop rule to loops (1) and (2) shown in Figure 26.21a to calculate R and \mathcal{E} . Travel around each loop in the direction shown.

(a) **SET UP:**

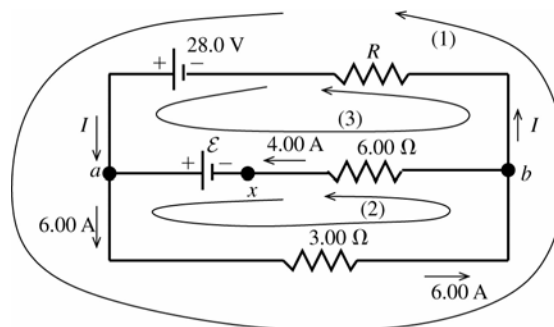

Figure 26.21a

EXECUTE: Apply Kirchoff's point rule to point a : $\sum I = 0$ so $I + 4.00 \text{ A} - 6.00 \text{ A} = 0$

$I = 2.00 \text{ A}$ (in the direction shown in the diagram).

(b) Apply Kirchoff's loop rule to loop (1): $-(6.00 \text{ A})(3.00 \Omega) - (2.00 \text{ A})R + 28.0 \text{ V} = 0$
 $-18.0 \text{ V} - (2.00 \Omega)R + 28.0 \text{ V} = 0$

$$R = \frac{28.0 \text{ V} - 18.0 \text{ V}}{2.00 \text{ A}} = 5.00 \Omega$$

(c) Apply Kirchoff's loop rule to loop (2): $-(6.00 \text{ A})(3.00 \Omega) - (4.00 \text{ A})(6.00 \Omega) + \mathcal{E} = 0$

$$\mathcal{E} = 18.0 \text{ V} + 24.0 \text{ V} = 42.0 \text{ V}$$

EVALUATE: Can check that the loop rule is satisfied for loop (3), as a check of our work:

$$28.0 \text{ V} - \mathcal{E} + (4.00 \text{ A})(6.00 \Omega) - (2.00 \text{ A})R = 0$$

$$28.0 \text{ V} - 42.0 \text{ V} + 24.0 \text{ V} - (2.00 \text{ A})(5.00 \Omega) = 0$$

$$52.0 \text{ V} = 42.0 \text{ V} + 10.0 \text{ V}$$

$$52.0 \text{ V} = 52.0 \text{ V}, \text{ so the loop rule is satisfied for this loop.}$$

(d) **IDENTIFY:** If the circuit is broken at point x there can be no current in the 6.00Ω resistor. There is now only a single current path and we can apply the loop rule to this path.

SET UP: The circuit is sketched in Figure 26.21b.

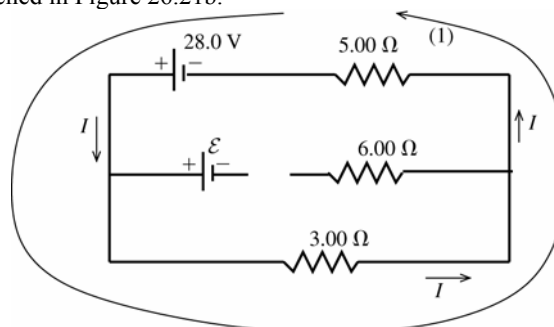

Figure 26.21b

EXECUTE: $+28.0 \text{ V} - (3.00 \Omega)I - (5.00 \Omega)I = 0$

$$I = \frac{28.0 \text{ V}}{8.00 \Omega} = 3.50 \text{ A}$$

EVALUATE: Breaking the circuit at x removes the 42.0 V emf from the circuit and the current through the 3.00Ω resistor is reduced.

26.22. IDENTIFY: Apply the loop rule and junction rule.

SET UP: The circuit diagram is given in Figure 26.22. The junction rule has been used to find the magnitude and direction of the current in the middle branch of the circuit. There are no remaining unknown currents.

EXECUTE: The loop rule applied to loop (1) gives:

$$+20.0 \text{ V} - (1.00 \text{ A})(1.00 \Omega) + (1.00 \text{ A})(4.00 \Omega) + (1.00 \text{ A})(1.00 \Omega) - \mathcal{E}_1 - (1.00 \text{ A})(6.00 \Omega) = 0$$

$$\mathcal{E}_1 = 20.0 \text{ V} - 1.00 \text{ V} + 4.00 \text{ V} + 1.00 \text{ V} - 6.00 \text{ V} = 18.0 \text{ V} .$$

The loop rule applied to loop (2) gives:

$$+20.0 \text{ V} - (1.00 \text{ A})(1.00 \Omega) - (2.00 \text{ A})(1.00 \Omega) - \mathcal{E}_2 - (2.00 \text{ A})(2.00 \Omega) - (1.00 \text{ A})(6.00 \Omega) = 0$$

$$\mathcal{E}_2 = 20.0 \text{ V} - 1.00 \text{ V} - 2.00 \text{ V} - 4.00 \text{ V} - 6.00 \text{ V} = 7.0 \text{ V} .$$

Going from b to a along the lower branch, $V_b + (2.00 \text{ A})(2.00 \Omega) + 7.0 \text{ V} + (2.00 \text{ A})(1.00 \Omega) = V_a$. $V_b - V_a = -13.0 \text{ V}$; point b is at 13.0 V lower potential than point a .

EVALUATE: We can also calculate $V_b - V_a$ by going from b to a along the upper branch of the circuit.

$V_b - (1.00 \text{ A})(6.00 \Omega) + 20.0 \text{ V} - (1.00 \text{ A})(1.00 \Omega) = V_a$ and $V_b - V_a = -13.0 \text{ V}$. This agrees with $V_b - V_a$ calculated along a different path between b and a .

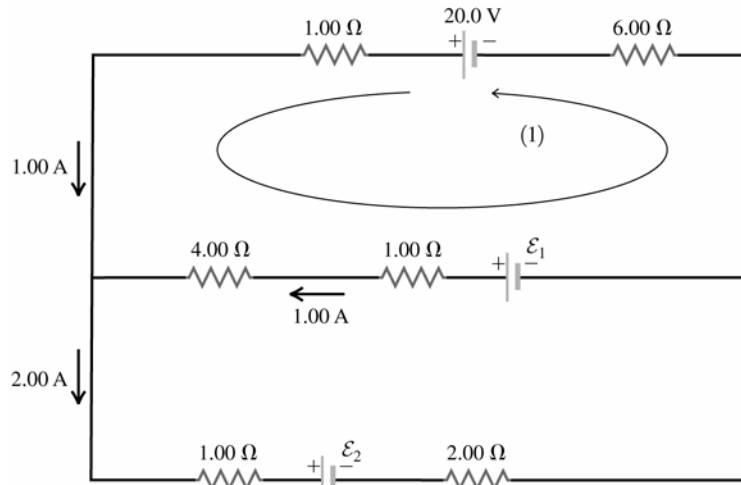

Figure 26.22

26.23. IDENTIFY: Apply the junction rule at points a , b , c and d to calculate the unknown currents. Then apply the loop rule to three loops to calculate \mathcal{E}_1 , \mathcal{E}_2 and R .

(a) SET UP: The circuit is sketched in Figure 26.23.

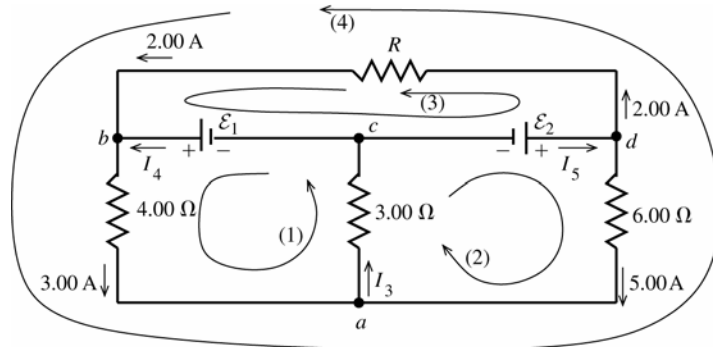

Figure 26.23

EXECUTE: Apply the junction rule to point a : $3.00 \text{ A} + 5.00 \text{ A} - I_3 = 0$

$$I_3 = 8.00 \text{ A}$$

Apply the junction rule to point b : $2.00 \text{ A} + I_4 - 3.00 \text{ A} = 0$

$$I_4 = 1.00 \text{ A}$$

Apply the junction rule to point c : $I_3 - I_4 - I_5 = 0$

$$I_5 = I_3 - I_4 = 8.00 \text{ A} - 1.00 \text{ A} = 7.00 \text{ A}$$

EVALUATE: As a check, apply the junction rule to point d : $I_5 - 2.00 \text{ A} - 5.00 \text{ A} = 0$

$$I_5 = 7.00 \text{ A}$$

(b) **EXECUTE:** Apply the loop rule to loop (1): $\mathcal{E}_1 - (3.00 \text{ A})(4.00 \Omega) - I_3(3.00 \Omega) = 0$

$$\mathcal{E}_1 = 12.0 \text{ V} + (8.00 \text{ A})(3.00 \Omega) = 36.0 \text{ V}$$

Apply the loop rule to loop (2): $\mathcal{E}_2 - (5.00 \text{ A})(6.00 \Omega) - I_3(3.00 \Omega) = 0$

$$\mathcal{E}_2 = 30.0 \text{ V} + (8.00 \text{ A})(3.00 \Omega) = 54.0 \text{ V}$$

(c) Apply the loop rule to loop (3): $-(2.00 \text{ A})R - \mathcal{E}_1 + \mathcal{E}_2 = 0$

$$R = \frac{\mathcal{E}_2 - \mathcal{E}_1}{2.00 \text{ A}} = \frac{54.0 \text{ V} - 36.0 \text{ V}}{2.00 \text{ A}} = 9.00 \Omega$$

EVALUATE: Apply the loop rule to loop (4) as a check of our calculations:

$$-(2.00 \text{ A})R - (3.00 \text{ A})(4.00 \Omega) + (5.00 \text{ A})(6.00 \Omega) = 0$$

$$-(2.00 \text{ A})(9.00 \Omega) - 12.0 \text{ V} + 30.0 \text{ V} = 0$$

$$-18.0 \text{ V} + 18.0 \text{ V} = 0$$

26.24. IDENTIFY: Use Kirchhoff's Rules to find the currents.

SET UP: Since the 1.0 V battery has the larger voltage, assume I_1 is to the left through the 10 V battery, I_2 is to the right through the 5 V battery, and I_3 is to the right through the 10 Ω resistor. Go around each loop in the counterclockwise direction.

EXECUTE: Upper loop: $10.0 \text{ V} - (2.00 \Omega + 3.00 \Omega)I_1 - (1.00 \Omega + 4.00 \Omega)I_2 - 5.00 \text{ V} = 0$. This gives

$$5.0 \text{ V} - (5.00 \Omega)I_1 - (5.00 \Omega)I_2 = 0, \text{ and } \Rightarrow I_1 + I_2 = 1.00 \text{ A}.$$

Lower loop: $5.00 \text{ V} + (1.00 \Omega + 4.00 \Omega)I_2 - (10.0 \Omega)I_3 = 0$. This gives $5.00 \text{ V} + (5.00 \Omega)I_2 - (10.0 \Omega)I_3 = 0$, and

$$I_2 - 2I_3 = -1.00 \text{ A}$$

Along with $I_1 = I_2 + I_3$, we can solve for the three currents and find:

$$I_1 = 0.800 \text{ A}, I_2 = 0.200 \text{ A}, I_3 = 0.600 \text{ A}.$$

(b) $V_{ab} = -(0.200 \text{ A})(4.00 \Omega) - (0.800 \text{ A})(3.00 \Omega) = -3.20 \text{ V}$.

EVALUATE: Traveling from b to a through the 4.00 Ω and 3.00 Ω resistors you pass through the resistors in the direction of the current and the potential decreases; point b is at higher potential than point a .

26.25. IDENTIFY: Apply the junction rule to reduce the number of unknown currents. Apply the loop rule to two loops to obtain two equations for the unknown currents I_1 and I_2

(a) **SET UP:** The circuit is sketched in Figure 26.25.

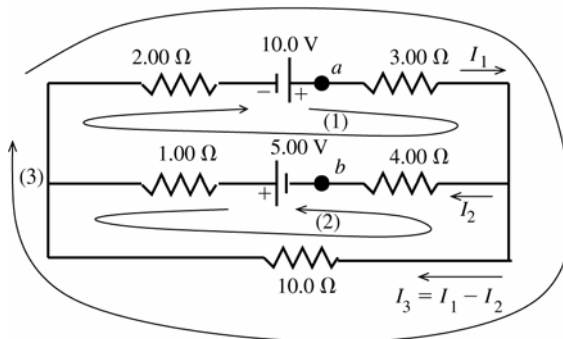

Figure 26.25

Let I_1 be the current in the 3.00 Ω resistor and I_2 be the current in the 4.00 Ω resistor and assume that these currents are in the directions shown. Then the current in the 10.0 Ω resistor is $I_3 = I_1 - I_2$, in the direction shown, where we have used Kirchhoff's point rule to relate I_3 to I_1 and I_2 . If we get a negative answer for any of these currents we know the current is actually in the opposite direction to what we have assumed. Three loops and directions to travel around the loops are shown in the circuit diagram. Apply Kirchhoff's loop rule to each loop.

EXECUTE: loop (1)

$$+10.0 \text{ V} - I_1(3.00 \Omega) - I_2(4.00 \Omega) + 5.00 \text{ V} - I_2(1.00 \Omega) - I_1(2.00 \Omega) = 0$$

$$15.0 \text{ V} - (5.00 \Omega)I_1 - (5.00 \Omega)I_2 = 0$$

$$3.00 \text{ A} - I_1 - I_2 = 0$$

loop (2)

$$+5.00 \text{ V} - I_2(1.00 \Omega) + (I_1 - I_2)10.0 \Omega - I_2(4.00 \Omega) = 0$$

$$5.00 \text{ V} + (10.0 \Omega)I_1 - (15.0 \Omega)I_2 = 0$$

$$1.00 \text{ A} + 2.00I_1 - 3.00I_2 = 0$$

The first equation says $I_2 = 3.00 \text{ A} - I_1$.

Use this in the second equation: $1.00 \text{ A} + 2.00I_1 - 9.00 \text{ A} + 3.00I_1 = 0$

$$5.00I_1 = 8.00 \text{ A}, I_1 = 1.60 \text{ A}$$

Then $I_2 = 3.00 \text{ A} - I_1 = 3.00 \text{ A} - 1.60 \text{ A} = 1.40 \text{ A}$.

$$I_3 = I_1 - I_2 = 1.60 \text{ A} - 1.40 \text{ A} = 0.20 \text{ A}$$

EVALUATE: Loop (3) can be used as a check.

$$+10.0 \text{ V} - (1.60 \text{ A})(3.00 \Omega) - (0.20 \text{ A})(10.00 \Omega) - (1.60 \text{ A})(2.00 \Omega) = 0$$

$$10.0 \text{ V} = 4.8 \text{ V} + 2.0 \text{ V} + 3.2 \text{ V}$$

$$10.0 \text{ V} = 10.0 \text{ V}$$

We find that with our calculated currents the loop rule is satisfied for loop (3). Also, all the currents came out to be positive, so the current directions in the circuit diagram are correct.

(b) IDENTIFY and SET UP: To find $V_{ab} = V_a - V_b$ start at point b and travel to point a . Many different routes can be taken from b to a and all must yield the same result for V_{ab} .

EXECUTE: Travel through the 4.00Ω resistor and then through the 3.00Ω resistor:

$$V_b + I_2(4.00 \Omega) + I_1(3.00 \Omega) = V_a$$

$$V_a - V_b = (1.40 \text{ A})(4.00 \Omega) + (1.60 \text{ A})(3.00 \Omega) = 5.60 \text{ V} + 4.8 \text{ V} = 10.4 \text{ V} \text{ (point } a \text{ is at higher potential than point } b)$$

EVALUATE: Alternatively, travel through the 5.00 V emf, the 1.00Ω resistor, the 2.00Ω resistor, and the 10.0 V emf.

$$V_b + 5.00 \text{ V} - I_2(1.00 \Omega) - I_1(2.00 \Omega) + 10.0 \text{ V} = V_a$$

$$V_a - V_b = 15.0 \text{ V} - (1.40 \text{ A})(1.00 \Omega) - (1.60 \text{ A})(2.00 \Omega) = 15.0 \text{ V} - 1.40 \text{ V} - 3.20 \text{ V} = 10.4 \text{ V}, \text{ the same as before.}$$

26.26. IDENTIFY: Use Kirchhoff's rules to find the currents

SET UP: Since the 20.0 V battery has the largest voltage, assume I_1 is to the right through the 10.0 V battery, I_2 is to the left through the 20.0 V battery, and I_3 is to the right through the 10Ω resistor. Go around each loop in the counterclockwise direction.

EXECUTE: Upper loop: $10.0 \text{ V} + (2.00 \Omega + 3.00 \Omega)I_1 + (1.00 \Omega + 4.00 \Omega)I_2 - 20.00 \text{ V} = 0$.

$$-10.0 \text{ V} + (5.00 \Omega)I_1 + (5.00 \Omega)I_2 = 0, \text{ so } I_1 + I_2 = +2.00 \text{ A.}$$

Lower loop: $20.00 \text{ V} - (1.00 \Omega + 4.00 \Omega)I_2 - (10.0 \Omega)I_3 = 0$.

$$20.00 \text{ V} - (5.00 \Omega)I_2 - (10.0 \Omega)I_3 = 0, \text{ so } I_2 + 2I_3 = 4.00 \text{ A.}$$

Along with $I_2 = I_1 + I_3$, we can solve for the three currents and find $I_1 = +0.4 \text{ A}$, $I_2 = +1.6 \text{ A}$, $I_3 = +1.2 \text{ A}$.

$$\text{(b) } V_{ab} = I_2(4 \Omega) + I_1(3 \Omega) = (1.6 \text{ A})(4 \Omega) + (0.4 \text{ A})(3 \Omega) = 7.6 \text{ V}$$

EVALUATE: Traveling from b to a through the 4.00Ω and 3.00Ω resistors you pass through each resistor opposite to the direction of the current and the potential increases; point a is at higher potential than point b .

26.27. (a) IDENTIFY: With the switch open, the circuit can be solved using series-parallel reduction.

SET UP: Find the current through the unknown battery using Ohm's law. Then use the equivalent resistance of the circuit to find the emf of the battery.

EXECUTE: The $30.0\text{-}\Omega$ and $50.0\text{-}\Omega$ resistors are in series, and hence have the same current. Using Ohm's law $I_{50} = (15.0 \text{ V})/(50.0 \Omega) = 0.300 \text{ A} = I_{30}$. The potential drop across the $75.0\text{-}\Omega$ resistor is the same as the potential drop across the $80.0\text{-}\Omega$ series combination. We can use this fact to find the current through the $75.0\text{-}\Omega$ resistor using Ohm's law: $V_{75} = V_{80} = (0.300 \text{ A})(80.0 \Omega) = 24.0 \text{ V}$ and $I_{75} = (24.0 \text{ V})/(75.0 \Omega) = 0.320 \text{ A}$.

The current through the unknown battery is the sum of the two currents we just found:

$$I_{\text{Total}} = 0.300 \text{ A} + 0.320 \text{ A} = 0.620 \text{ A}$$

The equivalent resistance of the resistors in parallel is $1/R_p = 1/(75.0 \Omega) + 1/(80.0 \Omega)$. This gives $R_p = 38.7 \Omega$. The equivalent resistance "seen" by the battery is $R_{\text{equiv}} = 20.0 \Omega + 38.7 \Omega = 58.7 \Omega$.

Applying Ohm's law to the battery gives $\mathcal{E} = R_{\text{equiv}}I_{\text{Total}} = (58.7 \Omega)(0.620 \text{ A}) = 36.4 \text{ V}$

(b) IDENTIFY: With the switch closed, the 25.0-V battery is connected across the $50.0\text{-}\Omega$ resistor.

SET UP: Taking a loop around the right part of the circuit.

EXECUTE: Ohm's law gives $I = (25.0 \text{ V})/(50.0 \Omega) = 0.500 \text{ A}$

EVALUATE: The current through the $50.0\text{-}\Omega$ resistor, and the rest of the circuit, depends on whether or not the switch is open.

26.28. IDENTIFY: We need to use Kirchhoff's rules.

SET UP: Take a loop around the outside of the circuit, use the current at the upper junction, and then take a loop around the right side of the circuit.

EXECUTE: The outside loop gives $75.0 \text{ V} - (12.0 \Omega)(1.50 \text{ A}) - (48.0 \Omega)I_{48} = 0$, so $I_{48} = 1.188 \text{ A}$. At a junction we have $1.50 \text{ A} = I_{\epsilon} + 1.188 \text{ A}$, and $I_{\epsilon} = 0.313 \text{ A}$. A loop around the right part of the circuit gives $\mathcal{E} - (48 \Omega)(1.188 \text{ A}) + (15.0 \Omega)(0.313 \text{ A})$. $\mathcal{E} = 52.3 \text{ V}$, with the polarity shown in the figure in the problem.

EVALUATE: The unknown battery has a smaller emf than the known one, so the current through it goes against its polarity.

26.29. (a) IDENTIFY: With the switch open, we have a series circuit with two batteries.

SET UP: Take a loop to find the current, then use Ohm's law to find the potential difference between a and b .

EXECUTE: Taking the loop: $I = (40.0 \text{ V})/(175 \Omega) = 0.229 \text{ A}$. The potential difference between a and b is $V_b - V_a = +15.0 \text{ V} - (75.0 \Omega)(0.229 \text{ A}) = -2.14 \text{ V}$.

EVALUATE: The minus sign means that a is at a higher potential than b .

(b) IDENTIFY: With the switch closed, the ammeter part of the circuit divides the original circuit into two circuits. We can apply Kirchhoff's rules to both parts.

SET UP: Take loops around the left and right parts of the circuit, and then look at the current at the junction.

EXECUTE: The left-hand loop gives $I_{100} = (25.0 \text{ V})/(100.0 \Omega) = 0.250 \text{ A}$. The right-hand loop gives $I_{75} = (15.0 \text{ V})/(75.0 \Omega) = 0.200 \text{ A}$. At the junction just above the switch we have $I_{100} = 0.250 \text{ A}$ (in) and $I_{75} = 0.200 \text{ A}$ (out), so $I_A = 0.250 \text{ A} - 0.200 \text{ A} = 0.050 \text{ A}$, downward. The voltmeter reads zero because the potential difference across it is zero with the switch closed.

EVALUATE: The ideal ammeter acts like a short circuit, making a and b at the same potential. Hence the voltmeter reads zero.

26.30. IDENTIFY: The circuit is sketched in Figure 26.30a. Since all the external resistors are equal, the current must be symmetrical through them. That is, there can be no current through the resistor R for that would imply an imbalance in currents through the other resistors. With no current going through R , the circuit is like that shown in Figure 26.30b.

SET UP: For resistors in series, the equivalent resistance is $R_s = R_1 + R_2$. For resistors in parallel, the equivalent

resistance is $\frac{1}{R_p} = \frac{1}{R_1} + \frac{1}{R_2}$

EXECUTE: The equivalent resistance of the circuit is $R_{\text{eq}} = \left(\frac{1}{2 \Omega} + \frac{1}{2 \Omega} \right)^{-1} = 1 \Omega$ and $I_{\text{total}} = \frac{13 \text{ V}}{1 \Omega} = 13 \text{ A}$. The two

parallel branches have the same resistance, so $I_{\text{each branch}} = \frac{1}{2} I_{\text{total}} = 6.5 \text{ A}$. The current through each 1Ω resistor is 6.5 A

and no current passes through R .

(b) As worked out above, $R_{\text{eq}} = 1 \Omega$.

(c) $V_{ab} = 0$, since no current flows through R .

EVALUATE: (d) R plays no role since no current flows through it and the voltage across it is zero.

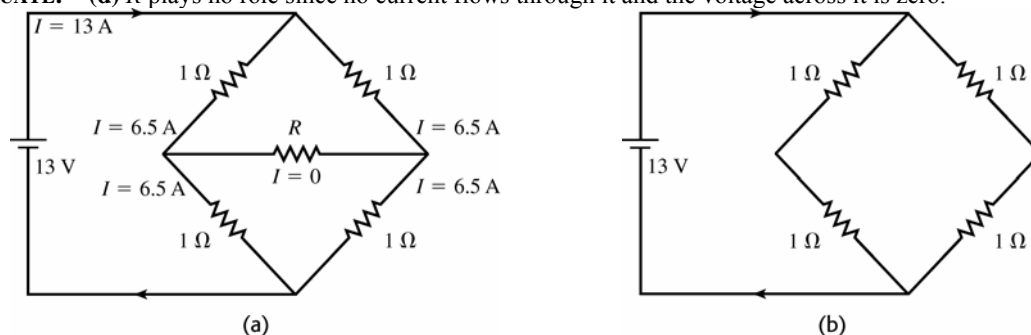

Figure 26.30

26.31. IDENTIFY: To construct an ammeter, add a shunt resistor in parallel with the galvanometer coil. To construct a voltmeter, add a resistor in series with the galvanometer coil.

SET UP: The full-scale deflection current is $500 \mu\text{A}$ and the coil resistance is 25.0Ω .

EXECUTE: (a) For a 20-mA ammeter, the two resistances are in parallel and the voltages across each are the same. $V_c = V_s$ gives $I_c R_c = I_s R_s$. $(500 \times 10^{-6} \text{ A})(25.0 \Omega) = (20 \times 10^{-3} \text{ A} - 500 \times 10^{-6} \text{ A})R_s$ and $R_s = 0.641 \Omega$.

(b) For a 500-mV voltmeter, the resistances are in series and the current is the same through each: $V_{ab} = I(R_c + R_s)$

$$\text{and } R_s = \frac{V_{ab}}{I} - R_c = \frac{500 \times 10^{-3} \text{ V}}{500 \times 10^{-6} \text{ A}} - 25.0 \Omega = 975 \Omega.$$

EVALUATE: The equivalent resistance of the voltmeter is $R_{\text{eq}} = R_s + R_c = 1000 \Omega$. The equivalent resistance of the ammeter is given by $\frac{1}{R_{\text{eq}}} = \frac{1}{R_{\text{sh}}} + \frac{1}{R_c}$ and $R_{\text{eq}} = 0.625 \Omega$. The voltmeter is a high-resistance device and the ammeter is a low-resistance device.

26.32. IDENTIFY: The galvanometer is represented in the circuit as a resistance R_c . Use the junction rule to relate the current through the galvanometer and the current through the shunt resistor. The voltage drop across each parallel path is the same; use this to write an equation for the resistance R .

SET UP: The circuit is sketched in Figure 26.32.

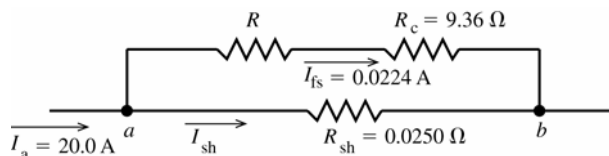

Figure 26.32

We want that $I_a = 20.0 \text{ A}$ in the external circuit to produce $I_{\text{fs}} = 0.0224 \text{ A}$ through the galvanometer coil.

EXECUTE: Applying the junction rule to point a gives $I_a - I_{\text{fs}} - I_{\text{sh}} = 0$

$$I_{\text{sh}} = I_a - I_{\text{fs}} = 20.0 \text{ A} - 0.0224 \text{ A} = 19.98 \text{ A}$$

The potential difference V_{ab} between points a and b must be the same for both paths between these two points:

$$I_{\text{fs}}(R + R_c) = I_{\text{sh}}R_{\text{sh}}$$

$$R = \frac{I_{\text{sh}}R_{\text{sh}}}{I_{\text{fs}}} - R_c = \frac{(19.98 \text{ A})(0.0250 \Omega)}{0.0224 \text{ A}} - 9.36 \Omega = 22.30 \Omega - 9.36 \Omega = 12.9 \Omega$$

EVALUATE: $R_{\text{sh}} \ll R + R_c$; most of the current goes through the shunt. Adding R decreases the fraction of the current that goes through R_c .

26.33. IDENTIFY: The meter introduces resistance into the circuit, which affects the current through the 5.00-k Ω resistor and hence the potential drop across it.

SET UP: Use Ohm's law to find the current through the 5.00-k Ω resistor and then the potential drop across it.

EXECUTE: (a) The parallel resistance with the voltmeter is 3.33 k Ω , so the total equivalent resistance across the battery is 9.33 k Ω , giving $I = (50.0 \text{ V})/(9.33 \text{ k}\Omega) = 5.36 \text{ mA}$. Ohm's law gives the potential drop across the 5.00-k Ω resistor: $V_{5 \text{ k}\Omega} = (3.33 \text{ k}\Omega)(5.36 \text{ mA}) = 17.9 \text{ V}$

(b) The current in the circuit is now $I = (50.0 \text{ V})/(11.0 \text{ k}\Omega) = 4.55 \text{ mA}$. $V_{5 \text{ k}\Omega} = (5.00 \text{ k}\Omega)(4.55 \text{ mA}) = 22.7 \text{ V}$.

(c) % error = $(22.7 \text{ V} - 17.9 \text{ V})/(22.7 \text{ V}) = 0.214 = 21.4\%$. (We carried extra decimal places for accuracy since we had to subtract our answers.)

EVALUATE: The presence of the meter made a very large percent error in the reading of the "true" potential across the resistor.

26.34. IDENTIFY: The resistance of the galvanometer can alter the resistance in a circuit.

SET UP: The shunt is in parallel with the galvanometer, so we find the parallel resistance of the ammeter. Then use Ohm's law to find the current in the circuit.

EXECUTE: (a) The resistance of the ammeter is given by $1/R_A = 1/(1.00 \Omega) + 1/(25.0 \Omega)$, so $R_A = 0.962 \Omega$. The current through the ammeter, and hence the current it measures, is $I = V/R = (25.0 \text{ V})/(15.96 \Omega) = 1.57 \text{ A}$.

(b) Now there is no meter in the circuit, so the total resistance is only 15.0 Ω . $I = (25.0 \text{ V})/(15.0 \Omega) = 1.67 \text{ A}$

(c) $(1.67 \text{ A} - 1.57 \text{ A})/(1.67 \text{ A}) = 0.060 = 6.0\%$

EVALUATE: A 1- Ω shunt can introduce noticeable error in the measurement of an ammeter.

26.35. IDENTIFY: When the galvanometer reading is zero $\mathcal{E}_2 = IR_{cb}$ and $\mathcal{E}_1 = IR_{ab}$.

SET UP: R_{cb} is proportional to x and R_{ab} is proportional to l .

$$\text{EXECUTE: (a) } \mathcal{E}_2 = \mathcal{E}_1 \frac{R_{cb}}{R_{ab}} = \mathcal{E}_1 \frac{x}{l}.$$

(b) The value of the galvanometer's resistance is unimportant since no current flows through it.

$$\text{(c) } \mathcal{E}_2 = \mathcal{E}_1 \frac{x}{l} = (9.15 \text{ V}) \frac{0.365 \text{ m}}{1.000 \text{ m}} = 3.34 \text{ V}$$

EVALUATE: The potentiometer measures the emf \mathcal{E}_2 of the source directly, unaffected by the internal resistance of the source, since the measurement is made with no current through \mathcal{E}_2 .

26.36. IDENTIFY: A half-scale reading occurs with $R = 600 \Omega$, so the current through the galvanometer is half the full-scale current.

SET UP: The resistors R_s , R_c and R are in series, so the total resistance of the circuit is $R_{\text{total}} = R_s + R_c + R$.

EXECUTE: $\mathcal{E} = IR_{\text{total}} \cdot 1.50 \text{ V} = \left(\frac{3.60 \times 10^{-3} \text{ A}}{2} \right) (15.0 \Omega + 600 \Omega + R_s)$ and $R_s = 218 \Omega$.

EVALUATE: We have assumed that the device is linear, in the sense that the deflection is proportional to the current through the meter.

26.37. IDENTIFY: Apply $\mathcal{E} = IR_{\text{total}}$ to relate the resistance R_x to the current in the circuit.

SET UP: R , R_x and the meter are in series, so $R_{\text{total}} = R + R_x + R_M$, where $R_M = 65.0 \Omega$ is the resistance of the meter. $I_{\text{fsd}} = 2.50 \text{ mA}$ is the current required for full-scale deflection.

EXECUTE: (a) When the wires are shorted, the full-scale deflection current is obtained: $\mathcal{E} = IR_{\text{total}}$.

$1.52 \text{ V} = (2.50 \times 10^{-3} \text{ A})(65.0 \Omega + R)$ and $R = 543 \Omega$.

(b) If the resistance $R_x = 200 \Omega$: $I = \frac{V}{R_{\text{total}}} = \frac{1.52 \text{ V}}{65.0 \Omega + 543 \Omega + R_x} = 1.88 \text{ mA}$.

(c) $I_x = \frac{\mathcal{E}}{R_{\text{total}}} = \frac{1.52 \text{ V}}{65.0 \Omega + 543 \Omega + R_x}$ and $R_x = \frac{1.52 \text{ V}}{I_x} - 608 \Omega$. For each value of I_x we have:

For $I_x = \frac{1}{4} I_{\text{fsd}} = 6.25 \times 10^{-4} \text{ A}$, $R_x = \frac{1.52 \text{ V}}{6.25 \times 10^{-4} \text{ A}} - 608 \Omega = 1824 \Omega$.

For $I_x = \frac{1}{2} I_{\text{fsd}} = 1.25 \times 10^{-3} \text{ A}$, $R_x = \frac{1.52 \text{ V}}{1.25 \times 10^{-3} \text{ A}} - 608 \Omega = 608 \Omega$.

For $I_x = \frac{3}{4} I_{\text{fsd}} = 1.875 \times 10^{-3} \text{ A}$, $R_x = \frac{1.52 \text{ V}}{1.875 \times 10^{-3} \text{ A}} - 608 \Omega = 203 \Omega$.

EVALUATE: The deflection of the meter increases when the resistance R_x decreases.

26.38. IDENTIFY: An uncharged capacitor is placed into a circuit. Apply the loop rule at each time.

SET UP: The voltage across a capacitor is $V_C = q/C$.

EXECUTE: (a) At the instant the circuit is completed, there is no voltage over the capacitor, since it has no charge stored.

(b) Since $V_C = 0$, the full battery voltage appears across the resistor $V_R = \mathcal{E} = 125 \text{ V}$.

(c) There is no charge on the capacitor.

(d) The current through the resistor is $i = \frac{\mathcal{E}}{R_{\text{total}}} = \frac{125 \text{ V}}{7500 \Omega} = 0.0167 \text{ A}$.

(e) After a long time has passed the full battery voltage is across the capacitor and $i = 0$. The voltage across the capacitor balances the emf: $V_C = 125 \text{ V}$. The voltage across the resistor is zero. The capacitor's charge is

$q = CV_C = (4.60 \times 10^{-6} \text{ F})(125 \text{ V}) = 5.75 \times 10^{-4} \text{ C}$. The current in the circuit is zero.

EVALUATE: The current in the circuit starts at 0.0167 A and decays to zero. The charge on the capacitor starts at zero and rises to $q = 5.75 \times 10^{-4} \text{ C}$.

26.39. IDENTIFY: The capacitor discharges exponentially through the voltmeter. Since the potential difference across the capacitor is directly proportional to the charge on the plates, the voltage across the plates decreases exponentially with the same time constant as the charge.

SET UP: The reading of the voltmeter obeys the equation $V = V_0 e^{-t/RC}$, where RC is the time constant.

EXECUTE: (a) Solving for C and evaluating the result when $t = 4.00 \text{ s}$ gives

$$C = \frac{t}{R \ln(V/V_0)} = \frac{4.00 \text{ s}}{(3.40 \times 10^6 \Omega) \ln\left(\frac{12.0 \text{ V}}{3.00 \text{ V}}\right)} = 8.49 \times 10^{-7} \text{ F}$$

(b) $\tau = RC = (3.40 \times 10^6 \Omega)(8.49 \times 10^{-7} \text{ F}) = 2.89 \text{ s}$

EVALUATE: In most laboratory circuits, time constants are much shorter than this one.

26.40. IDENTIFY: For a charging capacitor $q(t) = C\mathcal{E}(1 - e^{-t/\tau})$ and $i(t) = \frac{\mathcal{E}}{R} e^{-t/\tau}$.

SET UP: The time constant is $RC = (0.895 \times 10^6 \Omega)(12.4 \times 10^{-6} \text{ F}) = 11.1 \text{ s}$.

EXECUTE: (a) At $t = 0 \text{ s}$: $q = C\mathcal{E}(1 - e^{-t/RC}) = 0$.

$$\text{At } t = 5 \text{ s: } q = C\mathcal{E}(1 - e^{-t/RC}) = (12.4 \times 10^{-6} \text{ F})(60.0 \text{ V})(1 - e^{-(5.0 \text{ s})/(11.1 \text{ s})}) = 2.70 \times 10^{-4} \text{ C.}$$

$$\text{At } t = 10 \text{ s: } q = C\mathcal{E}(1 - e^{-t/RC}) = (12.4 \times 10^{-6} \text{ F})(60.0 \text{ V})(1 - e^{-(10.0 \text{ s})/(11.1 \text{ s})}) = 4.42 \times 10^{-4} \text{ C.}$$

$$\text{At } t = 20 \text{ s: } q = C\mathcal{E}(1 - e^{-t/RC}) = (12.4 \times 10^{-6} \text{ F})(60.0 \text{ V})(1 - e^{-(20.0 \text{ s})/(11.1 \text{ s})}) = 6.21 \times 10^{-4} \text{ C.}$$

$$\text{At } t = 100 \text{ s: } q = C\mathcal{E}(1 - e^{-t/RC}) = (12.4 \times 10^{-6} \text{ F})(60.0 \text{ V})(1 - e^{-(100 \text{ s})/(11.1 \text{ s})}) = 7.44 \times 10^{-4} \text{ C.}$$

(b) The current at time t is given by: $i = \frac{\mathcal{E}}{R} e^{-t/RC}$.

$$\text{At } t = 0 \text{ s: } i = \frac{60.0 \text{ V}}{8.95 \times 10^5 \Omega} e^{-0/11.1} = 6.70 \times 10^{-5} \text{ A.}$$

$$\text{At } t = 5 \text{ s: } i = \frac{60.0 \text{ V}}{8.95 \times 10^5 \Omega} e^{-5/11.1} = 4.27 \times 10^{-5} \text{ A.}$$

$$\text{At } t = 10 \text{ s: } i = \frac{60.0 \text{ V}}{8.95 \times 10^5 \Omega} e^{-10/11.1} = 2.27 \times 10^{-5} \text{ A.}$$

$$\text{At } t = 20 \text{ s: } i = \frac{60.0 \text{ V}}{8.95 \times 10^5 \Omega} e^{-20/11.1} = 1.11 \times 10^{-5} \text{ A.}$$

$$\text{At } t = 100 \text{ s: } i = \frac{60.0 \text{ V}}{8.95 \times 10^5 \Omega} e^{-100/11.1} = 8.20 \times 10^{-9} \text{ A.}$$

(c) The graphs of $q(t)$ and $i(t)$ are given in Figure 26.40a and 26.40b

EVALUATE: The charge on the capacitor increases in time as the current decreases.

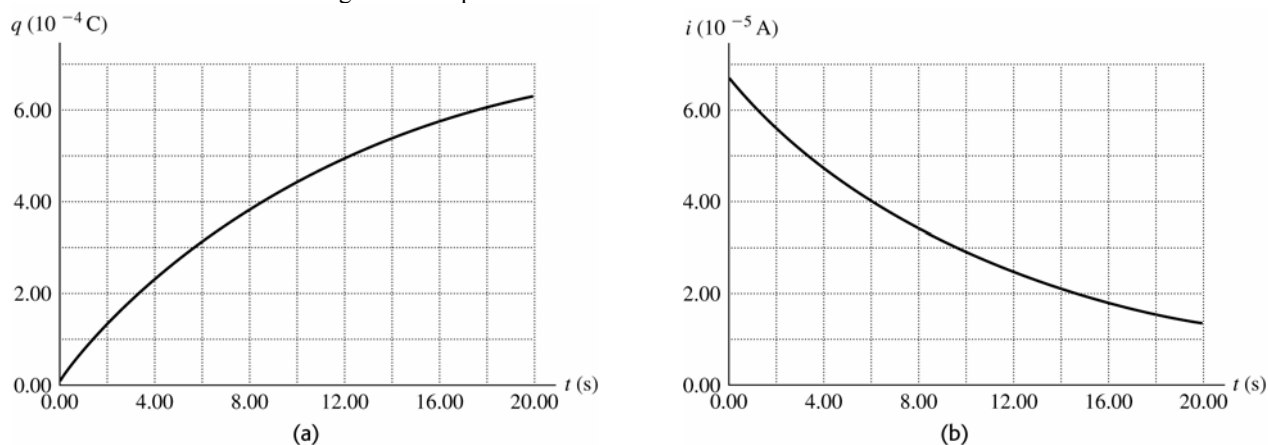

Figure 26.40

26.41. IDENTIFY: The capacitors, which are in parallel, will discharge exponentially through the resistors.

SET UP: Since V is proportional to Q , V must obey the same exponential equation as Q , $V = V_0 e^{-t/RC}$. The current is $I = (V_0/R) e^{-t/RC}$.

EXECUTE: (a) Solve for time when the potential across each capacitor is 10.0 V:

$$t = -RC \ln(V/V_0) = -(80.0 \Omega)(35.0 \mu\text{F}) \ln(10/45) = 4210 \mu\text{s} = 4.21 \text{ ms}$$

(b) $I = (V_0/R) e^{-t/RC}$. Using the above values, with $V_0 = 45.0 \text{ V}$, gives $I = 0.125 \text{ A}$.

EVALUATE: Since the current and the potential both obey the same exponential equation, they are both reduced by the same factor (0.222) in 4.21 ms.

26.42. IDENTIFY: In $\tau = RC$ use the equivalent capacitance of the two capacitors.

SET UP: For capacitors in series, $\frac{1}{C_{\text{eq}}} = \frac{1}{C_1} + \frac{1}{C_2}$. For capacitors in parallel, $C_{\text{eq}} = C_1 + C_2$. Originally,

$$\tau = RC = 0.870 \text{ s.}$$

EXECUTE: (a) The combined capacitance of the two identical capacitors in series is given by $\frac{1}{C_{\text{eq}}} = \frac{1}{C} + \frac{1}{C} = \frac{2}{C}$,

so $C_{\text{eq}} = \frac{C}{2}$. The new time constant is thus $R(C/2) = \frac{0.870 \text{ s}}{2} = 0.435 \text{ s}$.

(b) With the two capacitors in parallel the new total capacitance is simply $2C$. Thus the time constant is $R(2C) = 2(0.870 \text{ s}) = 1.74 \text{ s}$.

EVALUATE: The time constant is proportional to C_{eq} . For capacitors in series the capacitance is decreased and for capacitors in parallel the capacitance is increased.

- 26.43. IDENTIFY and SET UP:** Apply the loop rule. The voltage across the resistor depends on the current through it and the voltage across the capacitor depends on the charge on its plates.

$$\text{EXECUTE: } \mathcal{E} - V_R - V_C = 0$$

$$\mathcal{E} = 120 \text{ V}, V_R = IR = (0.900 \text{ A})(80.0 \Omega) = 72 \text{ V}, \text{ so } V_C = 48 \text{ V}$$

$$Q = CV = (4.00 \times 10^{-6} \text{ F})(48 \text{ V}) = 192 \mu\text{C}$$

EVALUATE: The initial charge is zero and the final charge is $C\mathcal{E} = 480 \mu\text{C}$. Since current is flowing at the instant considered in the problem the capacitor is still being charged and its charge has not reached its final value.

- 26.44. IDENTIFY:** The charge is increasing while the current is decreasing. Both obey exponential equations, but they are not the same equation.

SET UP: The charge obeys the equation $Q = Q_{\max}(1 - e^{-t/RC})$, but the equation for the current is $I = I_{\max}e^{-t/RC}$.

EXECUTE: When the charge has reached $\frac{1}{4}$ of its maximum value, we have $Q_{\max}/4 = Q_{\max}(1 - e^{-t/RC})$, which says that the exponential term has the value $e^{-t/RC} = \frac{3}{4}$. The current at this time is $I = I_{\max}e^{-t/RC} = I_{\max}(3/4) = (3/4)[(10.0 \text{ V})/(12.0 \Omega)] = 0.625 \text{ A}$

EVALUATE: Notice that the current will be $\frac{3}{4}$, not $\frac{1}{4}$, of its maximum value when the charge is $\frac{1}{4}$ of its maximum. Although current and charge both obey exponential equations, the equations have different forms for a charging capacitor.

- 26.45. IDENTIFY:** The stored energy is proportional to the square of the charge on the capacitor, so it will obey an exponential equation, but not the same equation as the charge.

SET UP: The energy stored in the capacitor is $U = Q^2/2C$ and the charge on the plates is $Q_0 e^{-t/RC}$. The current is $I = I_0 e^{-t/RC}$.

$$\text{EXECUTE: } U = Q^2/2C = (Q_0 e^{-t/RC})^2/2C = U_0 e^{-2t/RC}$$

When the capacitor has lost 80% of its stored energy, the energy is 20% of the initial energy, which is $U_0/5$. $U_0/5 = U_0 e^{-2t/RC}$ gives $t = (RC/2) \ln 5 = (25.0 \Omega)(4.62 \text{ pF})(\ln 5)/2 = 92.9 \text{ ps}$.

At this time, the current is $I = I_0 e^{-t/RC} = (Q_0/RC) e^{-t/RC}$, so

$$I = (3.5 \text{ nC})/[(25.0 \Omega)(4.62 \text{ pF})] e^{-(92.9 \text{ ps})/[(25.0 \Omega)(4.62 \text{ pF})]} = 13.6 \text{ A}.$$

EVALUATE: When the energy reduced by 80%, neither the current nor the charge are reduced by that percent.

- 26.46. IDENTIFY:** Both the charge and energy decay exponentially, but not with the same time constant since the energy is proportional to the *square* of the charge.

SET UP: The charge obeys the equation $Q = Q_0 e^{-t/RC}$ but the energy obeys the equation $U = Q^2/2C = (Q_0 e^{-t/RC})^2/2C = U_0 e^{-2t/RC}$.

EXECUTE: (a) The charge is reduced by half: $Q_0/2 = Q_0 e^{-t/RC}$. This gives

$$t = RC \ln 2 = (175 \Omega)(12.0 \mu\text{F})(\ln 2) = 1.456 \text{ ms} = 1.46 \text{ ms}.$$

(b) The energy is reduced by half: $U_0/2 = U_0 e^{-2t/RC}$. This gives

$$t = (RC \ln 2)/2 = (1.456 \text{ ms})/2 = 0.728 \text{ ms}.$$

EVALUATE: The energy decreases faster than the charge because it is proportional to the square of the charge.

- 26.47. IDENTIFY:** In both cases, simplify the complicated circuit by eliminating the appropriate circuit elements. The potential across an uncharged capacitor is initially zero, so it behaves like a short circuit. A fully charged capacitor allows no current to flow through it.

(a) SET UP: Just after closing the switch, the uncharged capacitors all behave like short circuits, so any resistors in parallel with them are eliminated from the circuit.

EXECUTE: The equivalent circuit consists of 50Ω and 25Ω in parallel, with this combination in series with 75Ω , 15Ω , and the 100-V battery. The equivalent resistance is $90 \Omega + 16.7 \Omega = 106.7 \Omega$, which gives $I = (100 \text{ V})/(106.7 \Omega) = 0.937 \text{ A}$.

(b) SET UP: Long after closing the switch, the capacitors are essentially charged up and behave like open circuits since no charge can flow through them. They effectively eliminate any resistors in series with them since no current can flow through these resistors.

EXECUTE: The equivalent circuit consists of resistances of 75Ω , 15Ω , and three $25\text{-}\Omega$ resistors, all in series with the 100-V battery, for a total resistance of 165Ω . Therefore $I = (100 \text{ V})/(165 \Omega) = 0.606 \text{ A}$

EVALUATE: The initial and final behavior of the circuit can be calculated quite easily using simple series-parallel circuit analysis. Intermediate times would require much more difficult calculations!

- 26.48. IDENTIFY:** When the capacitor is fully charged the voltage V across the capacitor equals the battery emf and

$$Q = CV. \text{ For a charging capacitor, } q = Q(1 - e^{-t/RC}).$$

SET UP: $\ln e^x = x$

EXECUTE: (a) $Q = CV = (5.90 \times 10^{-6} \text{ F})(28.0 \text{ V}) = 1.65 \times 10^{-4} \text{ C}$.

(b) $q = Q(1 - e^{-t/RC})$, so $e^{-t/RC} = 1 - \frac{q}{Q}$ and $R = \frac{-t}{C \ln(1 - q/Q)}$. After

$$t = 3 \times 10^{-3} \text{ s: } R = \frac{-3 \times 10^{-3} \text{ s}}{(5.90 \times 10^{-6} \text{ F})(\ln(1 - 110/165))} = 463 \Omega.$$

(c) If the charge is to be 99% of final value: $\frac{q}{Q} = (1 - e^{-t/RC})$ gives

$$t = -RC \ln(1 - q/Q) = -(463 \Omega)(5.90 \times 10^{-6} \text{ F}) \ln(0.01) = 0.0126 \text{ s}.$$

EVALUATE: The time constant is $\tau = RC = 2.73 \text{ ms}$. The time in part (b) is a bit more than one time constant and the time in part (c) is about 4.6 time constants.

26.49. IDENTIFY: For each circuit apply the loop rule to relate the voltages across the circuit elements.

(a) **SET UP:** With the switch in position 2 the circuit is the charging circuit shown in Figure 26.49a.

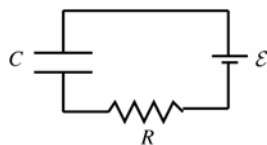

At $t = 0$, $q = 0$.

Figure 26.49a

EXECUTE: The charge q on the capacitor is given as a function of time by Eq.(26.12):

$$q = C\mathcal{E}(1 - e^{-t/RC})$$

$$Q_f = C\mathcal{E} = (1.50 \times 10^{-5} \text{ F})(18.0 \text{ V}) = 2.70 \times 10^{-4} \text{ C}.$$

$$RC = (980 \Omega)(1.50 \times 10^{-5} \text{ F}) = 0.0147 \text{ s}$$

$$\text{Thus, at } t = 0.0100 \text{ s, } q = (2.70 \times 10^{-4} \text{ C})\left(1 - e^{-(0.0100 \text{ s})/(0.0147 \text{ s})}\right) = 133 \mu\text{C}.$$

$$(b) v_C = \frac{q}{C} = \frac{133 \mu\text{C}}{1.50 \times 10^{-5} \text{ F}} = 8.87 \text{ V}$$

The loop rule says $\mathcal{E} - v_C - v_R = 0$

$$v_R = \mathcal{E} - v_C = 18.0 \text{ V} - 8.87 \text{ V} = 9.13 \text{ V}$$

(c) **SET UP:** Throwing the switch back to position 1 produces the discharging circuit shown in Figure 26.49b.

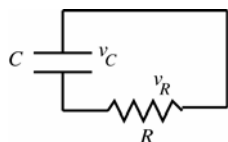

The initial charge Q_0 is the charge calculated in part (b),
 $Q_0 = 133 \mu\text{C}$.

Figure 26.49b

EXECUTE: $v_C = \frac{q}{C} = \frac{133 \mu\text{C}}{1.50 \times 10^{-5} \text{ F}} = 8.87 \text{ V}$, the same as just before the switch is thrown. But now

$$v_C - v_R = 0, \text{ so } v_R = v_C = 8.87 \text{ V}.$$

(d) **SET UP:** In the discharging circuit the charge on the capacitor as a function of time is given by Eq.(26.16):

$$q = Q_0 e^{-t/RC}.$$

EXECUTE: $RC = 0.0147 \text{ s}$, the same as in part (a). Thus at $t = 0.0100 \text{ s}$, $q = (133 \mu\text{C})e^{-(0.0100 \text{ s})/(0.0147 \text{ s})} = 67.4 \mu\text{C}$.

EVALUATE: $t = 10.0 \text{ ms}$ is less than one time constant, so at the instant described in part (a) the capacitor is not fully charged; its voltage (8.87 V) is less than the emf. There is a charging current and a voltage drop across the resistor. In the discharging circuit the voltage across the capacitor starts at 8.87 V and decreases. After $t = 10.0 \text{ ms}$ it has decreased to $v_C = q/C = 4.49 \text{ V}$.

26.50. IDENTIFY: $P = VI = I^2 R$

SET UP: Problem 25.77 says that for 12-gauge wire the maximum safe current is 2.5 A.

EXECUTE: (a) $I = \frac{P}{V} = \frac{4100 \text{ W}}{240 \text{ V}} = 17.1 \text{ A}$. So we need at least 14-gauge wire (good up to 18 A). 12 gauge is also ok (good up to 25 A).

$$(b) P = \frac{V^2}{R} \text{ and } R = \frac{V^2}{P} = \frac{(240 \text{ V})^2}{4100 \text{ W}} = 14 \Omega.$$

$$(c) \text{ At } 11\text{¢ per kWh, for 1 hour the cost is } (11\text{¢/kWh})(1 \text{ h})(4.1 \text{ kW}) = 45\text{¢}.$$

EVALUATE: The cost to operate the device is proportional to its power consumption.

- 26.51. IDENTIFY and SET UP:** The heater and hair dryer are in parallel so the voltage across each is 120 V and the current through the fuse is the sum of the currents through each appliance. As the power consumed by the dryer increases the current through it increases. The maximum power setting is the highest one for which the current through the fuse is less than 20 A.

EXECUTE: Find the current through the heater. $P = VI$ so $I = P/V = 1500 \text{ W}/120 \text{ V} = 12.5 \text{ A}$. The maximum total current allowed is 20 A, so the current through the dryer must be less than $20 \text{ A} - 12.5 \text{ A} = 7.5 \text{ A}$. The power dissipated by the dryer if the current has this value is $P = VI = (120 \text{ V})(7.5 \text{ A}) = 900 \text{ W}$. For P at this value or larger the circuit breaker trips.

EVALUATE: $P = V^2/R$ and for the dryer V is a constant 120 V. The higher power settings correspond to a smaller resistance R and larger current through the device.

- 26.52. IDENTIFY:** The current gets split evenly between all the parallel bulbs.

SET UP: A single bulb will draw $I = \frac{P}{V} = \frac{90 \text{ W}}{120 \text{ V}} = 0.75 \text{ A}$.

EXECUTE: Number of bulbs $\leq \frac{20 \text{ A}}{0.75 \text{ A}} = 26.7$. So you can attach 26 bulbs safely.

EVALUATE: In parallel the voltage across each bulb is the circuit voltage.

- 26.53. IDENTIFY and SET UP:** Ohm's law and Eq.(25.18) can be used to calculate I and P given V and R . Use Eq.(25.12) to calculate the resistance at the higher temperature.

(a) **EXECUTE:** When the heater element is first turned on it is at room temperature and has resistance $R = 20 \Omega$.

$$I = \frac{V}{R} = \frac{120 \text{ V}}{20 \Omega} = 6.0 \text{ A}$$

$$P = \frac{V^2}{R} = \frac{(120 \text{ V})^2}{20 \Omega} = 720 \text{ W}$$

(b) Find the resistance $R(T)$ of the element at the operating temperature of 280°C .

Take $T_0 = 23.0^\circ\text{C}$ and $R_0 = 20 \Omega$. Eq.(25.12) gives

$$R(T) = R_0(1 + \alpha(T - T_0)) = 20 \Omega \left(1 + (2.8 \times 10^{-3} (\text{C}^\circ)^{-1})(280^\circ\text{C} - 23.0^\circ\text{C}) \right) = 34.4 \Omega.$$

$$I = \frac{V}{R} = \frac{120 \text{ V}}{34.4 \Omega} = 3.5 \text{ A}$$

$$P = \frac{V^2}{R} = \frac{(120 \text{ V})^2}{34.4 \Omega} = 420 \text{ W}$$

EVALUATE: When the temperature increases, R increases and I and P decrease. The changes are substantial.

- 26.54. (a) IDENTIFY:** Two of the resistors in series would each dissipate one-half the total, or 1.2 W, which is ok. But the series combination would have an equivalent resistance of 800Ω , not the 400Ω that is required. Resistors in parallel have an equivalent resistance that is less than that of the individual resistors, so a solution is two in series in parallel with another two in series.

SET UP: The network can be simplified as shown in Figure 26.54a.

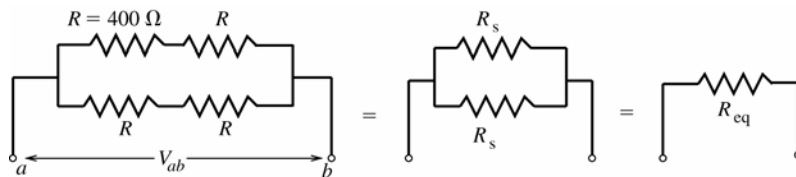

Figure 26.54a

EXECUTE: R_s is the resistance equivalent to two of the 400Ω resistors in series. $R_s = R + R = 800 \Omega$. R_{eq} is

the resistance equivalent to the two $R_s = 800 \Omega$ resistors in parallel: $\frac{1}{R_{\text{eq}}} = \frac{1}{R_s} + \frac{1}{R_s} = \frac{2}{R_s}$; $R_{\text{eq}} = \frac{800 \Omega}{2} = 400 \Omega$.

EVALUATE: This combination does have the required 400Ω equivalent resistance. It will be shown in part (b) that a total of 2.4 W can be dissipated without exceeding the power rating of each individual resistor.

IDENTIFY: Another solution is two resistors in parallel in series with two more in parallel.

SET UP: The network can be simplified as shown in Figure 26.54b.

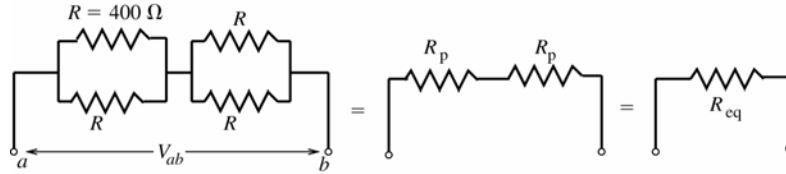

Figure 26.54b

EXECUTE: $\frac{1}{R_p} = \frac{1}{R} + \frac{1}{R} = \frac{2}{400 \Omega}$; $R_p = 200 \Omega$; $R_{eq} = R_p + R_p = 400 \Omega$

EVALUATE: This combination has the required 400Ω equivalent resistance. It will be shown in part (b) that a total of 2.4 W can be dissipated without exceeding the power rating of each individual resistor.

(b) IDENTIFY and SET UP: Find the applied voltage V_{ab} such that a total of 2.4 W is dissipated and then for this V_{ab} find the power dissipated by each resistor.

EXECUTE: For a combination with equivalent resistance $R_{eq} = 400 \Omega$ to dissipate 2.4 W the voltage V_{ab} applied to the network must be given by $P = V_{ab}^2 / R_{eq}$ so $V_{ab} = \sqrt{PR_{eq}} = \sqrt{(2.4 \text{ W})(400 \Omega)} = 31.0 \text{ V}$ and the current through the equivalent resistance is $I = V_{ab} / R = 31.0 \text{ V} / 400 \Omega = 0.0775 \text{ A}$. For the first combination this means 31.0 V across each parallel branch and $\frac{1}{2}(31.0 \text{ V}) = 15.5 \text{ V}$ across each 400Ω resistor. The power dissipated by each individual resistor is then $P = V^2 / R = (15.5 \text{ V})^2 / 400 \Omega = 0.60 \text{ W}$, which is less than the maximum allowed value of 1.20 W . For the second combination this means a voltage of $IR_p = (0.0775 \text{ A})(200 \Omega) = 15.5 \text{ V}$ across each parallel combination and hence across each separate resistor. The power dissipated by each resistor is again $P = V^2 / R = (15.5 \text{ V})^2 / 400 \Omega = 0.60 \text{ W}$, which is less than the maximum allowed value of 1.20 W .

EVALUATE: The symmetry of each network says that each resistor in the network dissipates the same power. So, for a total of 2.4 W dissipated by the network, each resistor dissipates $(2.4 \text{ W}) / 4 = 0.60 \text{ W}$, which agrees with the above analysis.

26.55. IDENTIFY: The Cu and Ni cables are in parallel. For each, $R = \frac{\rho L}{A}$.

SET UP: The composite cable is sketched in Figure 26.55. The cross sectional area of the nickel segment is πa^2 and the area of the copper portion is $\pi(b^2 - a^2)$. For nickel $\rho = 7.8 \times 10^{-8} \Omega \cdot \text{m}$ and for copper $\rho = 1.72 \times 10^{-8} \Omega \cdot \text{m}$.

EXECUTE: $\frac{1}{R_{\text{Cable}}} = \frac{1}{R_{\text{Ni}}} + \frac{1}{R_{\text{Cu}}}$. $R_{\text{Ni}} = \rho_{\text{Ni}} L / A = \rho_{\text{Ni}} \frac{L}{\pi a^2}$ and $R_{\text{Cu}} = \rho_{\text{Cu}} L / A = \rho_{\text{Cu}} \frac{L}{\pi(b^2 - a^2)}$. Therefore,

$$\frac{1}{R_{\text{cable}}} = \frac{\pi a^2}{\rho_{\text{Ni}} L} + \frac{\pi(b^2 - a^2)}{\rho_{\text{Cu}} L}$$

$$\frac{1}{R_{\text{cable}}} = \frac{\pi}{L} \left(\frac{a^2}{\rho_{\text{Ni}}} + \frac{b^2 - a^2}{\rho_{\text{Cu}}} \right) = \frac{\pi}{20 \text{ m}} \left[\frac{(0.050 \text{ m})^2}{7.8 \times 10^{-8} \Omega \cdot \text{m}} + \frac{(0.100 \text{ m})^2 - (0.050 \text{ m})^2}{1.72 \times 10^{-8} \Omega \cdot \text{m}} \right] \text{ and } R_{\text{cable}} = 13.6 \times 10^{-6} \Omega = 13.6 \mu\Omega$$

(b) $R = \rho_{\text{eff}} \frac{L}{A} = \rho_{\text{eff}} \frac{L}{\pi b^2}$. This gives $\rho_{\text{eff}} = \frac{\pi b^2 R}{L} = \frac{\pi(0.10 \text{ m})^2 (13.6 \times 10^{-6} \Omega)}{20 \text{ m}} = 2.14 \times 10^{-8} \Omega \cdot \text{m}$

EVALUATE: The effective resistivity of the cable is about 25% larger than the resistivity of copper. If nickel had infinite resistivity and only the copper portion conducted, the resistance of the cable would be $14.6 \mu\Omega$, which is not much larger than the resistance calculated in part (a).

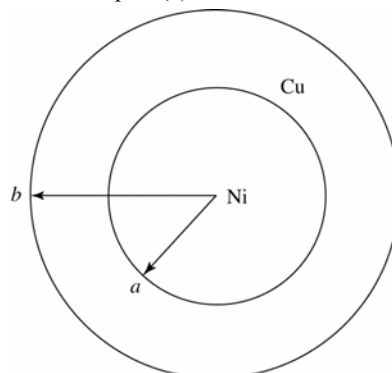

Figure 26.55

- 26.56. IDENTIFY and SET UP:** Let $R = 1.00 \Omega$, the resistance of one wire. Each half of the wire has $R_h = R/2 = 0.500 \Omega$. The combined wires are the same as a resistor network. Use the rules for equivalent resistance for resistors in series and parallel to find the resistance of the network, as shown in Figure 26.56.
EXECUTE:

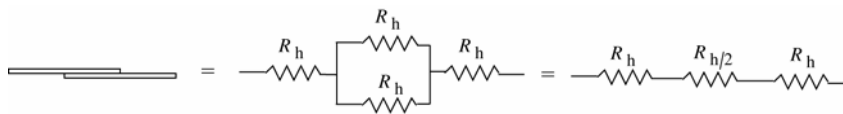

Figure 26.56

The equivalent resistance is $R_h + R_h/2 + R_h = 5R_h/2 = \frac{5}{2}(0.500 \Omega) = 1.25 \Omega$

EVALUATE: If the two wires were connected end-to-end, the total resistance would be 2.00Ω . If they were joined side-by-side, the total resistance would be 0.500Ω . Our answer is between these two limiting values.

- 26.57. IDENTIFY:** The terminal voltage of the battery depends on the current through it and therefore on the equivalent resistance connected to it. The power delivered to each bulb is $P = I^2R$, where I is the current through it.

SET UP: The terminal voltage of the source is $\mathcal{E} - Ir$.

EXECUTE: (a) The equivalent resistance of the two bulbs is 1.0Ω . This equivalent resistance is in series with the

internal resistance of the source, so the current through the battery is $I = \frac{V}{R_{\text{total}}} = \frac{8.0 \text{ V}}{1.0 \Omega + 0.80 \Omega} = 4.4 \text{ A}$ and the

current through each bulb is 2.2 A . The voltage applied to each bulb is $\mathcal{E} - Ir = 8.0 \text{ V} - (4.4 \text{ A})(0.80 \Omega) = 4.4 \text{ V}$.

Therefore, $P_{\text{bulb}} = I^2R = (2.2 \text{ A})^2(2.0 \Omega) = 9.7 \text{ W}$.

(b) If one bulb burns out, then $I = \frac{V}{R_{\text{total}}} = \frac{8.0 \text{ V}}{2.0 \Omega + 0.80 \Omega} = 2.9 \text{ A}$. The current through the remaining bulb is

2.9 A , and $P = I^2R = (2.9 \text{ A})^2(2.0 \Omega) = 16.3 \text{ W}$. The remaining bulb is brighter than before, because it is consuming more power.

EVALUATE: In Example 26.2 the internal resistance of the source is negligible and the brightness of the remaining bulb doesn't change when one burns out.

- 26.58. IDENTIFY:** Half the current flows through each parallel resistor and the full current flows through the third resistor, that is in series with the parallel combination. Therefore, only the series resistor will be at its maximum power.

SET UP: $P = I^2R$

EXECUTE: The maximum allowed power is when the total current is the maximum allowed value of $I = \sqrt{P/R} = \sqrt{36 \text{ W}/2.4 \Omega} = 3.9 \text{ A}$. Then half the current flows through the parallel resistors and the maximum power is $P_{\text{max}} = (I/2)^2R + (I/2)^2R + I^2R = \frac{3}{2}I^2R = \frac{3}{2}(3.9 \text{ A})^2(2.4 \Omega) = 54 \text{ W}$.

EVALUATE: If all three resistors were in series or all three were in parallel, then the maximum power would be $3(36 \text{ W}) = 108 \text{ W}$. For the network in this problem, the maximum power is half this value.

- 26.59. IDENTIFY:** The ohmmeter reads the equivalent resistance between points a and b . Replace series and parallel combinations by their equivalent.

SET UP: For resistors in parallel, $\frac{1}{R_{\text{eq}}} = \frac{1}{R_1} + \frac{1}{R_2}$. For resistors in series, $R_{\text{eq}} = R_1 + R_2$

EXECUTE: Circuit (a): The 75.0Ω and 40.0Ω resistors are in parallel and have equivalent resistance 26.09Ω . The 25.0Ω and 50.0Ω resistors are in parallel and have an equivalent resistance of 16.67Ω . The equivalent

network is given in Figure 26.59a. $\frac{1}{R_{\text{eq}}} = \frac{1}{100.0 \Omega} + \frac{1}{23.05 \Omega}$, so $R_{\text{eq}} = 18.7 \Omega$.

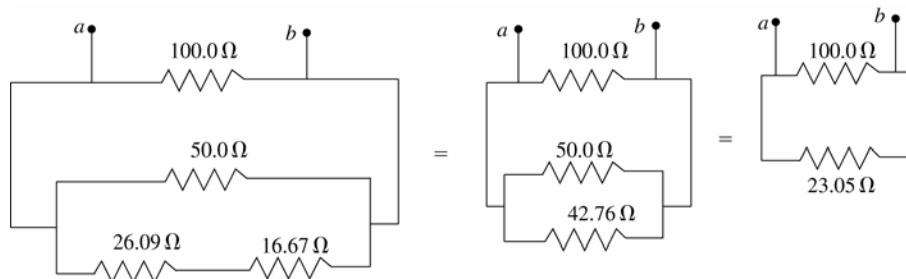

Figure 26.59a

Circuit (b): The $30.0\ \Omega$ and $45.0\ \Omega$ resistors are in parallel and have equivalent resistance $18.0\ \Omega$. The

equivalent network is given in Figure 26.59b. $\frac{1}{R_{\text{eq}}} = \frac{1}{10.0\ \Omega} + \frac{1}{30.3\ \Omega}$, so $R_{\text{eq}} = 7.5\ \Omega$.

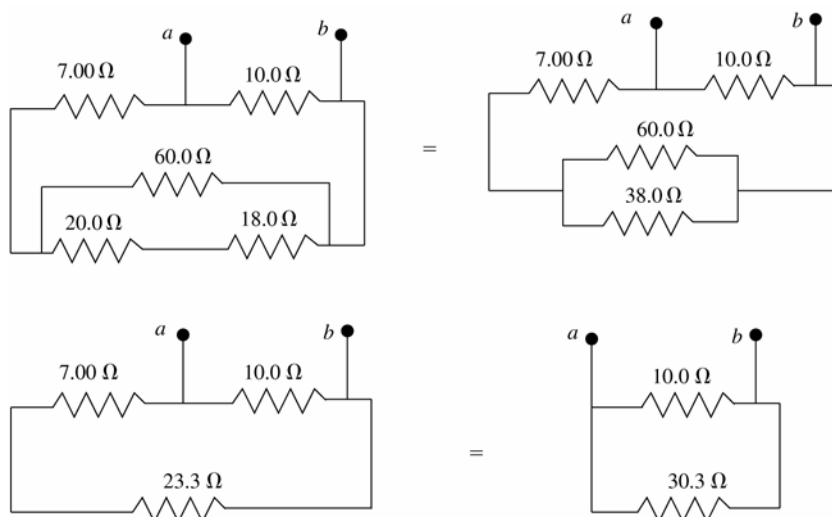

Figure 26.59b

EVALUATE: In circuit (a) the resistance along one path between a and b is $100.0\ \Omega$, but that is not the equivalent resistance between these points. A similar comment can be made about circuit (b).

26.60. IDENTIFY: Heat, which is generated in the resistor, melts the ice.

SET UP: Find the rate at which heat is generated in the $20.0\text{-}\Omega$ resistor using $P = V^2/R$. Then use the heat of fusion of ice to find the rate at which the ice melts. The heat dH to melt a mass of ice dm is $dH = L_F dm$, where L_F is the latent heat of fusion. The rate at which heat enters the ice, dH/dt , is the power P in the resistor, so $P = L_F dm/dt$. Therefore the rate of melting of the ice is $dm/dt = P/L_F$.

EXECUTE: The equivalent resistance of the parallel branch is $5.00\ \Omega$, so the total resistance in the circuit is $35.0\ \Omega$. Therefore the total current in the circuit is $I_{\text{Total}} = (45.0\ \text{V})/(35.0\ \Omega) = 1.286\ \text{A}$. The potential difference across the $20.0\text{-}\Omega$ resistor in the ice is the same as the potential difference across the parallel branch: $V_{\text{ice}} = I_{\text{Total}}R_p = (1.286\ \text{A})(5.00\ \Omega) = 6.429\ \text{V}$. The rate of heating of the ice is $P_{\text{ice}} = V_{\text{ice}}^2/R = (6.429\ \text{V})^2/(20.0\ \Omega) = 2.066\ \text{W}$. This power goes into to heat to melt the ice, so

$$dm/dt = P/L_F = (2.066\ \text{W})/(3.34 \times 10^5\ \text{J/kg}) = 6.19 \times 10^{-6}\ \text{kg/s} = 6.19 \times 10^{-3}\ \text{g/s}$$

EVALUATE: The melt rate is about $6\ \text{mg/s}$, which is not much. It would take $1000\ \text{s}$ to melt just $6\ \text{g}$ of ice.

26.61. IDENTIFY: Apply the junction rule to express the currents through the $5.00\ \Omega$ and $8.00\ \Omega$ resistors in terms of I_1, I_2 and I_3 . Apply the loop rule to three loops to get three equations in the three unknown currents.

SET UP: The circuit is sketched in Figure 26.61.

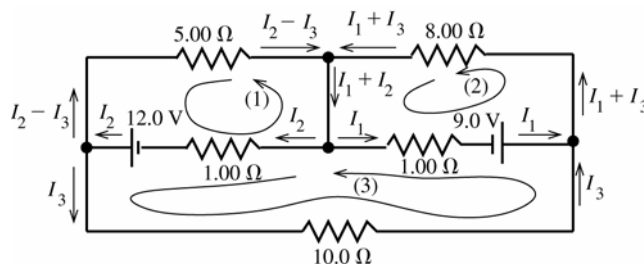

Figure 26.61

The current in each branch has been written in terms of I_1, I_2 and I_3 such that the junction rule is satisfied at each junction point.

EXECUTE: Apply the loop rule to loop (1).

$$-12.0\ \text{V} + I_2(1.00\ \Omega) + (I_2 - I_3)(5.00\ \Omega) = 0$$

$$I_2(6.00\ \Omega) - I_3(5.00\ \Omega) = 12.0\ \text{V} \quad \text{eq.(1)}$$

Apply the loop rule to loop (2).

$$-I_1(1.00 \Omega) + 9.00 \text{ V} - (I_1 + I_3)(8.00 \Omega) = 0$$

$$I_1(9.00 \Omega) + I_3(8.00 \Omega) = 9.00 \text{ V} \quad \text{eq.(2)}$$

Apply the loop rule to loop (3).

$$-I_3(10.0 \Omega) - 9.00 \text{ V} + I_1(1.00 \Omega) - I_2(1.00 \Omega) + 12.0 \text{ V} = 0$$

$$-I_1(1.00 \Omega) + I_2(1.00 \Omega) + I_3(10.0 \Omega) = 3.00 \text{ V} \quad \text{eq.(3)}$$

Eq.(1) gives $I_2 = 2.00 \text{ A} + \frac{5}{6}I_3$; eq.(2) gives $I_1 = 1.00 \text{ A} - \frac{8}{9}I_3$

Using these results in eq.(3) gives $-(1.00 \text{ A} - \frac{8}{9}I_3)(1.00 \Omega) + (2.00 \text{ A} + \frac{5}{6}I_3)(1.00 \Omega) + I_3(10.0 \Omega) = 3.00 \text{ V}$

$$\left(\frac{16+15+180}{18}\right)I_3 = 2.00 \text{ A}; I_3 = \frac{18}{211}(2.00 \text{ A}) = 0.171 \text{ A}$$

Then $I_2 = 2.00 \text{ A} + \frac{5}{6}I_3 = 2.00 \text{ A} + \frac{5}{6}(0.171 \text{ A}) = 2.14 \text{ A}$ and $I_1 = 1.00 \text{ A} - \frac{8}{9}I_3 = 1.00 \text{ A} - \frac{8}{9}(0.171 \text{ A}) = 0.848 \text{ A}$.

EVALUATE: We could check that the loop rule is satisfied for a loop that goes through the 5.00Ω , 8.00Ω and 10.0Ω resistors. Going around the loop clockwise: $-(I_2 - I_3)(5.00 \Omega) + (I_1 + I_3)(8.00 \Omega) + I_3(10.0 \Omega) = -9.85 \text{ V} + 8.15 \text{ V} + 1.71 \text{ V}$, which does equal zero, apart from rounding.

26.62. IDENTIFY: Apply the junction rule and the loop rule to the circuit.

SET UP: Because of the polarity of each emf, the current in the 7.00Ω resistor must be in the direction shown in Figure 26.62a. Let I be the current in the 24.0 V battery.

EXECUTE: The loop rule applied to loop (1) gives: $+24.0 \text{ V} - (1.80 \text{ A})(7.00 \Omega) - I(3.00 \Omega) = 0$. $I = 3.80 \text{ A}$. The junction rule then says that the current in the middle branch is 2.00 A , as shown in Figure 26.62b. The loop rule applied to loop (2) gives: $+\mathcal{E} - (1.80 \text{ A})(7.00 \Omega) + (2.00 \text{ A})(2.00 \Omega) = 0$ and $\mathcal{E} = 8.6 \text{ V}$.

EVALUATE: We can check our results by applying the loop rule to loop (3) in Figure 26.62b:

$+24.0 \text{ V} - \mathcal{E} - (2.00 \text{ A})(2.00 \Omega) - (3.80 \text{ A})(3.00 \Omega) = 0$ and $\mathcal{E} = 24.0 \text{ V} - 4.0 \text{ V} - 11.4 \text{ V} = 8.6 \text{ V}$, which agrees with our result from loop (2).

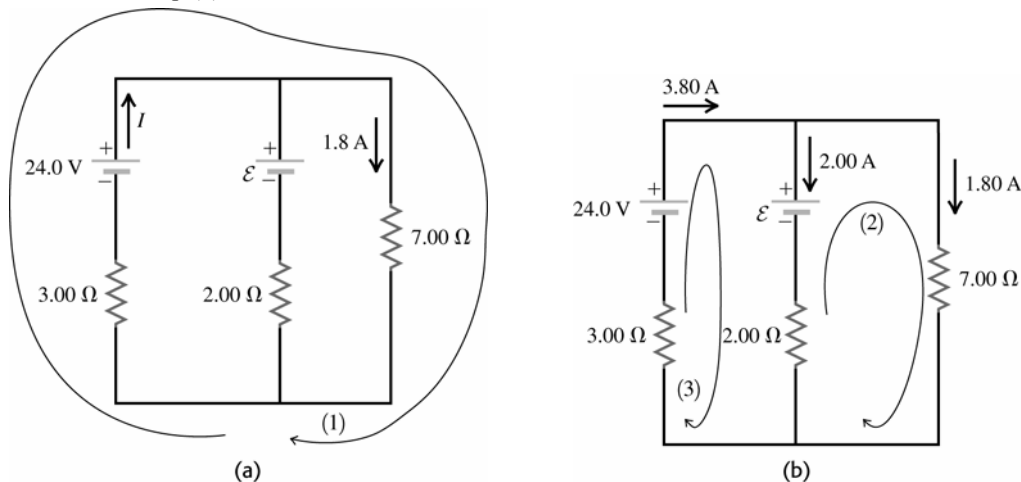

Figure 26.62

26.63. IDENTIFY and SET UP: The circuit is sketched in Figure 26.63.

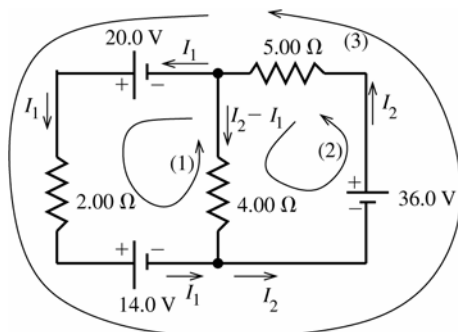

Figure 26.63

Two unknown currents I_1 (through the 2.00Ω resistor) and I_2 (through the 5.00Ω resistor) are labeled on the circuit diagram. The current through the 4.00Ω resistor has been written as $I_2 - I_1$ using the junction rule.

Apply the loop rule to loops (1) and (2) to get two equations for the unknown currents, I_1 and I_2 . Loop (3) can then be used to check the results.

EXECUTE: loop (1): $+20.0 \text{ V} - I_1(2.00 \Omega) - 14.0 \text{ V} + (I_2 - I_1)(4.00 \Omega) = 0$

$$6.00I_1 - 4.00I_2 = 6.00 \text{ A}$$

$$3.00I_1 - 2.00I_2 = 3.00 \text{ A} \quad \text{eq.(1)}$$

loop (2): $+36.0 \text{ V} - I_2(5.00 \Omega) - (I_2 - I_1)(4.00 \Omega) = 0$

$$-4.00I_1 + 9.00I_2 = 36.0 \text{ A} \quad \text{eq.(2)}$$

Solving eq. (1) for I_1 gives $I_1 = 1.00 \text{ A} + \frac{2}{3}I_2$

Using this in eq.(2) gives $-4.00(1.00 \text{ A} + \frac{2}{3}I_2) + 9.00I_2 = 36.0 \text{ A}$

$$(-\frac{8}{3} + 9.00)I_2 = 40.0 \text{ A} \text{ and } I_2 = 6.32 \text{ A.}$$

Then $I_1 = 1.00 \text{ A} + \frac{2}{3}I_2 = 1.00 \text{ A} + \frac{2}{3}(6.32 \text{ A}) = 5.21 \text{ A.}$

In summary then

Current through the 2.00Ω resistor: $I_1 = 5.21 \text{ A.}$

Current through the 5.00Ω resistor: $I_2 = 6.32 \text{ A.}$

Current through the 4.00Ω resistor: $I_2 - I_1 = 6.32 \text{ A} - 5.21 \text{ A} = 1.11 \text{ A.}$

EVALUATE: Use loop (3) to check. $+20.0 \text{ V} - I_1(2.00 \Omega) - 14.0 \text{ V} + 36.0 \text{ V} - I_2(5.00 \Omega) = 0$

$$(5.21 \text{ A})(2.00 \Omega) + (6.32 \text{ A})(5.00 \Omega) = 42.0 \text{ V}$$

$10.4 \text{ V} + 31.6 \text{ V} = 42.0 \text{ V}$, so the loop rule is satisfied for this loop.

26.64. IDENTIFY: Apply the loop and junction rules.

SET UP: Use the currents as defined on the circuit diagram in Figure 26.64 and obtain three equations to solve for the currents.

EXECUTE: Left loop: $14 - I_1 - 2(I_1 - I_2) = 0$ and $3I_1 - 2I_2 = 14$.

Top loop: $-2(I - I_1) + I_2 + I_1 = 0$ and $-2I + 3I_1 + I_2 = 0$.

Bottom loop: $-(I - I_1 + I_2) + 2(I_1 - I_2) - I_2 = 0$ and $-I + 3I_1 - 4I_2 = 0$.

Solving these equations for the currents we find: $I = I_{\text{battery}} = 10.0 \text{ A}$; $I_1 = I_{R_1} = 6.0 \text{ A}$; $I_2 = I_{R_3} = 2.0 \text{ A}$.

So the other currents are: $I_{R_2} = I - I_1 = 4.0 \text{ A}$; $I_{R_4} = I_1 - I_2 = 4.0 \text{ A}$; $I_{R_5} = I - I_1 + I_2 = 6.0 \text{ A}$.

(b) $R_{\text{eq}} = \frac{V}{I} = \frac{14.0 \text{ V}}{10.0 \text{ A}} = 1.40 \Omega$.

EVALUATE: It isn't possible to simplify the resistor network using the rules for resistors in series and parallel. But the equivalent resistance is still defined by $V = IR_{\text{eq}}$.

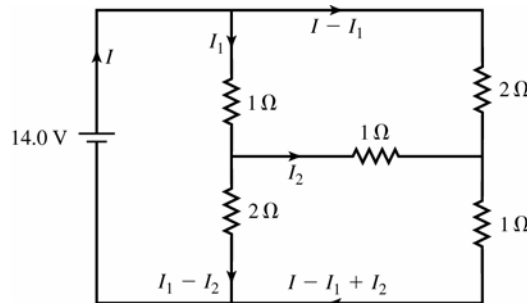

Figure 26.64

26.65. (a) IDENTIFY: Break the circuit between points a and b means no current in the middle branch that contains the 3.00Ω resistor and the 10.0 V battery. The circuit therefore has a single current path. Find the current, so that potential drops across the resistors can be calculated. Calculate V_{ab} by traveling from a to b , keeping track of the potential changes along the path taken.

SET UP: The circuit is sketched in Figure 26.65a.

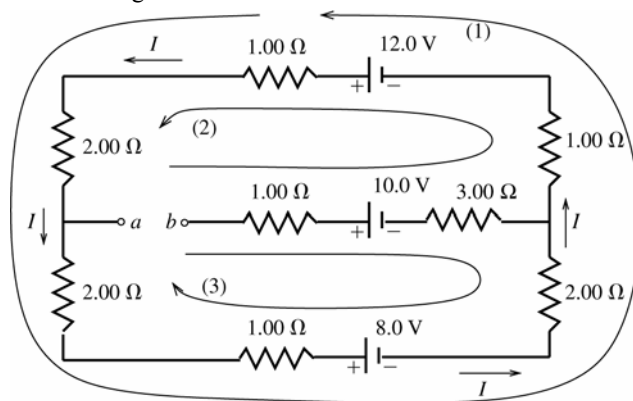

Figure 26.65a

EXECUTE: Apply the loop rule to loop (1).

$$+12.0 \text{ V} - I(1.00 \Omega + 2.00 \Omega + 2.00 \Omega + 1.00 \Omega) - 8.0 \text{ V} - I(2.00 \Omega + 1.00 \Omega) = 0$$

$$I = \frac{12.0 \text{ V} - 8.0 \text{ V}}{9.00 \Omega} = 0.4444 \text{ A.}$$

To find V_{ab} start at point b and travel to a , adding up the potential rises and drops. Travel on path (2) shown on the diagram. The 1.00Ω and 3.00Ω resistors in the middle branch have no current through them and hence no voltage across them. Therefore, $V_b - 10.0 \text{ V} + 12.0 \text{ V} - I(1.00 \Omega + 1.00 \Omega + 2.00 \Omega) = V_a$; thus

$$V_a - V_b = 2.0 \text{ V} - (0.4444 \text{ A})(4.00 \Omega) = +0.22 \text{ V} \quad (\text{point } a \text{ is at higher potential})$$

EVALUATE: As a check on this calculation we also compute V_{ab} by traveling from b to a on path (3).

$$V_b - 10.0 \text{ V} + 8.0 \text{ V} + I(2.00 \Omega + 1.00 \Omega + 2.00 \Omega) = V_a$$

$$V_{ab} = -2.00 \text{ V} + (0.4444 \text{ A})(5.00 \Omega) = +0.22 \text{ V, which checks.}$$

(b) IDENTIFY and SET UP: With points a and b connected by a wire there are three current branches, as shown in Figure 26.65b.

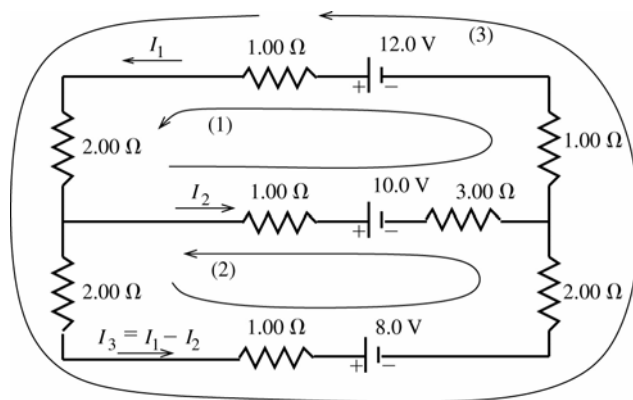

Figure 26.65b

The junction rule has been used to write the third current (in the 8.0 V battery) in terms of the other currents. Apply the loop rule to loops (1) and (2) to obtain two equations for the two unknowns I_1 and I_2 .

EXECUTE: Apply the loop rule to loop (1).

$$12.0 \text{ V} - I_1(1.00 \Omega) - I_1(2.00 \Omega) - I_2(1.00 \Omega) - 10.0 \text{ V} - I_2(3.00 \Omega) - I_1(1.00 \Omega) = 0$$

$$2.0 \text{ V} - I_1(4.00 \Omega) - I_2(4.00 \Omega) = 0$$

$$(2.00 \Omega)I_1 + (2.00 \Omega)I_2 = 1.0 \text{ V} \quad \text{eq.(1)}$$

Apply the loop rule to loop (2).

$$-(I_1 - I_2)(2.00 \Omega) - (I_1 - I_2)(1.00 \Omega) - 8.0 \text{ V} - (I_1 - I_2)(2.00 \Omega) + I_2(3.00 \Omega) + 10.0 \text{ V} + I_2(1.00 \Omega) = 0$$

$$2.0 \text{ V} - (5.00 \Omega)I_1 + (9.00 \Omega)I_2 = 0 \quad \text{eq.(2)}$$

Solve eq.(1) for I_2 and use this to replace I_2 in eq.(2).

$$I_2 = 0.50 \text{ A} - I_1$$

$$2.0 \text{ V} - (5.00 \Omega)I_1 + (9.00 \Omega)(0.50 \text{ A} - I_1) = 0$$

$$(14.0 \Omega)I_1 = 6.50 \text{ V} \text{ so } I_1 = (6.50 \text{ V})/(14.0 \Omega) = 0.464 \text{ A}$$

$$I_2 = 0.500 \text{ A} - 0.464 \text{ A} = 0.036 \text{ A}.$$

The current in the 12.0 V battery is $I_1 = 0.464 \text{ A}$.

EVALUATE: We can apply the loop rule to loop (3) as a check.

$$+12.0 \text{ V} - I_1(1.00 \Omega + 2.00 \Omega + 1.00 \Omega) - (I_1 - I_2)(2.00 \Omega + 1.00 \Omega + 2.00 \Omega) - 8.0 \text{ V} = 4.0 \text{ V} - 1.86 \text{ V} - 2.14 \text{ V} = 0,$$

as it should.

- 26.66. IDENTIFY:** Simplify the resistor networks as much as possible using the rule for series and parallel combinations of resistors. Then apply Kirchhoff's laws.

SET UP: First do the series/parallel reduction. This gives the circuit in Figure 26.66. The rate at which the 10.0Ω resistor generates thermal energy is $P = I^2 R$.

EXECUTE: Apply Kirchhoff's laws and solve for \mathcal{E} . $\Delta V_{\text{adefa}} = 0: -(20 \Omega)(2 \text{ A}) - 5 \text{ V} - (20 \Omega)I_2 = 0$.

This gives $I_2 = -2.25 \text{ A}$. Then $I_1 + I_2 = 2 \text{ A}$ gives $I_1 = 2 \text{ A} - (-2.25 \text{ A}) = 4.25 \text{ A}$.

$\Delta V_{\text{abcdefa}} = 0: (15 \Omega)(4.25 \text{ A}) + \mathcal{E} - (20 \Omega)(-2.25 \text{ A}) = 0$. This gives $\mathcal{E} = -109 \text{ V}$. Since \mathcal{E} is calculated to be negative, its polarity should be reversed.

(b) The parallel network that contains the 10.0Ω resistor in one branch has an equivalent resistance of 10Ω . The voltage across each branch of the parallel network is $V_{\text{par}} = RI = (10 \Omega)(2 \text{ A}) = 20 \text{ V}$. The current in the upper

branch is $I = \frac{V}{R} = \frac{20 \text{ V}}{30 \Omega} = \frac{2}{3} \text{ A}$. $Pt = E$, so $I^2 Rt = E$, where $E = 60.0 \text{ J}$. $(\frac{2}{3} \text{ A})^2 (10 \Omega)t = 60 \text{ J}$, and $t = 13.5 \text{ s}$.

EVALUATE: For the 10.0Ω resistor, $P = I^2 R = 4.44 \text{ W}$. The total rate at which electrical energy is input to the circuit in the emf is $(5.0 \text{ V})(2.0 \text{ A}) + (109 \text{ V})(4.25 \text{ A}) = 473 \text{ J}$. Only a small fraction of the energy is dissipated in the 10.0Ω resistor.

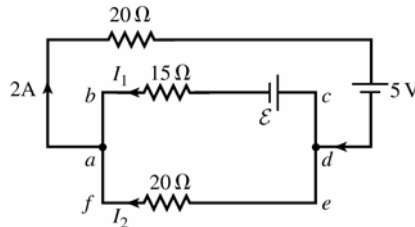

Figure 26.66

- 26.67. IDENTIFY:** In Figure 26.67, points a and c are at the same potential and points d and b are at the same potential, so we can calculate V_{ab} by calculating V_{cd} . We know the current through the resistor that is between points c and d . We thus can calculate the terminal voltage of the 24.0 V battery without calculating the current through it.

SET UP:

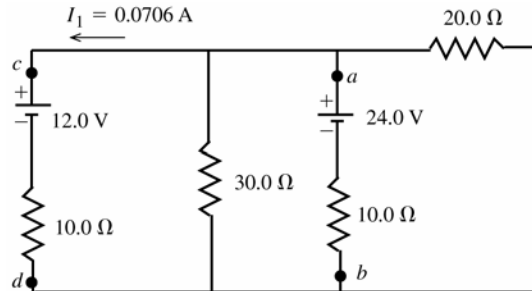

Figure 26.67

EXECUTE: $V_d + I_1(10.0 \Omega) + 12.0 \text{ V} = V_c$

$$V_c - V_d = 12.7 \text{ V}; V_a - V_b = V_c - V_d = 12.7 \text{ V}$$

EVALUATE: The voltage across each parallel branch must be the same. The current through the 24.0 V battery must be $(24.0 \text{ V} - 12.7 \text{ V})/(10.0 \Omega) = 1.13 \text{ A}$ in the direction b to a .

- 26.68. IDENTIFY:** The current through the $40.0\ \Omega$ resistor equals the current through the emf, and the current through each of the other resistors is less than or equal to this current. So, set $P_{40} = 1.00\ \text{W}$ and use this to solve for the current I through the emf. If $P_{40} = 1.00\ \text{W}$, then P for each of the other resistors is less than $1.00\ \text{W}$.
- SET UP:** Use the equivalent resistance for series and parallel combinations to simplify the circuit.
- EXECUTE:** $I^2 R = P$ gives $I^2(40\ \Omega) = 1\ \text{W}$, and $I = 0.158\ \text{A}$. Now use series / parallel reduction to simplify the circuit. The upper parallel branch is $6.38\ \Omega$ and the lower one is $25\ \Omega$. The series sum is now $126\ \Omega$. Ohm's law gives $\mathcal{E} = (126\ \Omega)(0.158\ \text{A}) = 19.9\ \text{V}$.
- EVALUATE:** The power input from the emf is $\mathcal{E}I = 3.14\ \text{W}$, so nearly one-third of the total power is dissipated in the $40.0\ \Omega$ resistor.
- 26.69. IDENTIFY and SET UP:** Simplify the circuit by replacing the parallel networks of resistors by their equivalents. In this simplified circuit apply the loop and junction rules to find the current in each branch.
- EXECUTE:** The $20.0\text{-}\Omega$ and $30.0\text{-}\Omega$ resistors are in parallel and have equivalent resistance $12.0\ \Omega$. The two resistors R are in parallel and have equivalent resistance $R/2$. The circuit is equivalent to the circuit sketched in Figure 26.69.

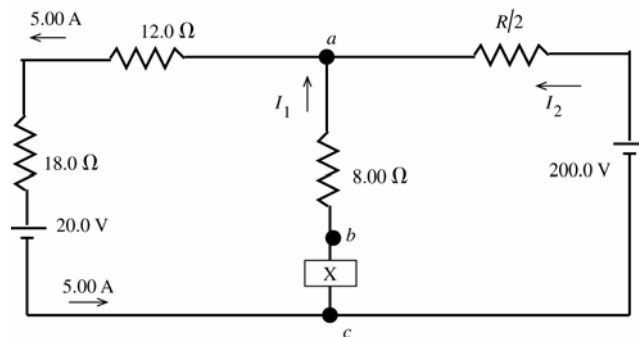

Figure 26.69

- (a) Calculate V_{ca} by traveling along the branch that contains the $20.0\ \text{V}$ battery, since we know the current in that branch.

$$V_a - (5.00\ \text{A})(12.0\ \Omega) - (5.00\ \text{A})(18.0\ \Omega) - 20.0\ \text{V} = V_c$$

$$V_a - V_c = 20.0\ \text{V} + 90.0\ \text{V} + 60.0\ \text{V} = 170.0\ \text{V}$$

$$V_b - V_a = V_{ab} = 16.0\ \text{V}$$

$$X - V_{ba} = 170.0\ \text{V} \text{ so } X = 186.0\ \text{V}, \text{ with the upper terminal } +$$

- (b) $I_1 = (16.0\ \text{V}) / (8.0\ \Omega) = 2.00\ \text{A}$

The junction rule applied to point a gives $I_2 + I_1 = 5.00\ \text{A}$, so $I_2 = 3.00\ \text{A}$. The current through the $200.0\ \text{V}$ battery is in the direction from the $-$ to the $+$ terminal, as shown in the diagram.

- (c) $200.0\ \text{V} - I_2(R/2) = 170.0\ \text{V}$

$$(3.00\ \text{A})(R/2) = 30.0\ \text{V} \text{ so } R = 20.0\ \Omega$$

EVALUATE: We can check the loop rule by going clockwise around the outer circuit loop. This gives $+20.0\ \text{V} + (5.00\ \text{A})(18.0\ \Omega + 12.0\ \Omega) + (3.00\ \text{A})(10.0\ \Omega) - 200.0\ \text{V} = 20.0\ \text{V} + 150.0\ \text{V} + 30.0\ \text{V} - 200.0\ \text{V}$, which does equal zero.

- 26.70. IDENTIFY:** $P_{\text{tot}} = \frac{V^2}{R_{\text{eq}}}$.

SET UP: Let R be the resistance of each resistor.

EXECUTE: When the resistors are in series, $R_{\text{eq}} = 3R$ and $P_s = \frac{V^2}{3R}$. When the resistors are in parallel, $R_{\text{eq}} = R/3$.

$$P_p = \frac{V^2}{R/3} = 3 \frac{V^2}{R} = 9P_s = 9(27\ \text{W}) = 243\ \text{W}.$$

EVALUATE: In parallel, the voltage across each resistor is the full applied voltage V . In series, the voltage across each resistor is $V/3$ and each resistor dissipates less power.

26.71. IDENTIFY and SET UP: For part (a) use that the full emf is across each resistor. In part (b), calculate the power dissipated by the equivalent resistance, and in this expression express R_1 and R_2 in terms of P_1 , P_2 and \mathcal{E} .

EXECUTE: $P_1 = \mathcal{E}^2 / R_1$ so $R_1 = \mathcal{E}^2 / P_1$

$P_2 = \mathcal{E}^2 / R_2$ so $R_2 = \mathcal{E}^2 / P_2$

(a) When the resistors are connected in parallel to the emf, the voltage across each resistor is \mathcal{E} and the power dissipated by each resistor is the same as if only the one resistor were connected. $P_{\text{tot}} = P_1 + P_2$

(b) When the resistors are connected in series the equivalent resistance is $R_{\text{eq}} = R_1 + R_2$

$$P_{\text{tot}} = \frac{\mathcal{E}^2}{R_1 + R_2} = \frac{\mathcal{E}^2}{\mathcal{E}^2 / P_1 + \mathcal{E}^2 / P_2} = \frac{P_1 P_2}{P_1 + P_2}$$

EVALUATE: The result in part (b) can be written as $\frac{1}{P_{\text{tot}}} = \frac{1}{P_1} + \frac{1}{P_2}$. Our results are that for parallel the powers add

and that for series the reciprocals of the power add. This is opposite the result for combining resistance. Since $P = \mathcal{E}^2 / R$ tells us that P is proportional to $1/R$, this makes sense.

26.72. IDENTIFY and SET UP: Just after the switch is closed the charge on the capacitor is zero, the voltage across the capacitor is zero and the capacitor can be replaced by a wire in analyzing the circuit. After a long time the current to the capacitor is zero, so the current through R_3 is zero. After a long time the capacitor can be replaced by a break in the circuit.

EXECUTE: (a) Ignoring the capacitor for the moment, the equivalent resistance of the two parallel resistors is

$$\frac{1}{R_{\text{eq}}} = \frac{1}{6.00 \Omega} + \frac{1}{3.00 \Omega} = \frac{3}{6.00 \Omega}; R_{\text{eq}} = 2.00 \Omega. \text{ In the absence of the capacitor, the total current in the circuit (the}$$

current through the 8.00Ω resistor) would be $i = \frac{\mathcal{E}}{R} = \frac{42.0 \text{ V}}{8.00 \Omega + 2.00 \Omega} = 4.20 \text{ A}$, of which $2/3$, or 2.80 A , would

go through the 3.00Ω resistor and $1/3$, or 1.40 A , would go through the 6.00Ω resistor. Since the current

through the capacitor is given by $i = \frac{V}{R} e^{-t/RC}$, at the instant $t = 0$ the circuit behaves as though the capacitor were

not present, so the currents through the various resistors are as calculated above.

(b) Once the capacitor is fully charged, no current flows through that part of the circuit. The 8.00Ω and the 6.00Ω resistors are now in series, and the current through them is $i = \mathcal{E}/R = (42.0 \text{ V})/(8.00 \Omega + 6.00 \Omega) = 3.00 \text{ A}$.

The voltage drop across both the 6.00Ω resistor and the capacitor is thus $V = iR = (3.00 \text{ A})(6.00 \Omega) = 18.0 \text{ V}$.

(There is no current through the 3.00Ω resistor and so no voltage drop across it.) The charge on the capacitor is

$$Q = CV = (4.00 \times 10^{-6} \text{ F})(18.0 \text{ V}) = 7.2 \times 10^{-5} \text{ C}.$$

EVALUATE: The equivalent resistance of R_2 and R_3 in parallel is less than R_3 , so initially the current through R_1 is larger than its value after a long time has elapsed.

26.73. (a) IDENTIFY and SET UP: The circuit is sketched in Figure 26.73a.

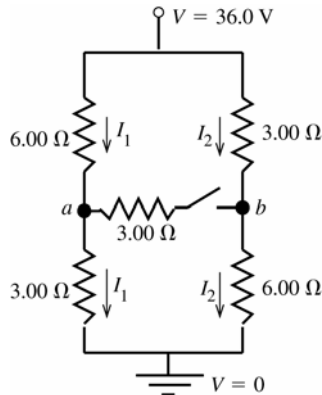

Figure 26.73a

With the switch open there is no current through it and there are only the two currents I_1 and I_2 indicated in the sketch.

The potential drop across each parallel branch is 36.0 V . Use this fact to calculate I_1 and I_2 . Then travel from point a to point b and keep track of the potential rises and drops in order to calculate V_{ab} .

EXECUTE: $-I_1(6.00\ \Omega + 3.00\ \Omega) + 36.0\ \text{V} = 0$

$$I_1 = \frac{36.0\ \text{V}}{6.00\ \Omega + 3.00\ \Omega} = 4.00\ \text{A}$$

$-I_2(3.00\ \Omega + 6.00\ \Omega) + 36.0\ \text{V} = 0$

$$I_2 = \frac{36.0\ \text{V}}{3.00\ \Omega + 6.00\ \Omega} = 4.00\ \text{A}$$

To calculate $V_{ab} = V_a - V_b$ start at point b and travel to point a , adding up all the potential rises and drops along the way. We can do this by going from b up through the $3.00\ \Omega$ resistor:

$$V_b + I_2(3.00\ \Omega) - I_1(6.00\ \Omega) = V_a$$

$$V_a - V_b = (4.00\ \text{A})(3.00\ \Omega) - (4.00\ \text{A})(6.00\ \Omega) = 12.0\ \text{V} - 24.0\ \text{V} = -12.0\ \text{V}$$

$$V_{ab} = -12.0\ \text{V} \text{ (point } a \text{ is } 12.0\ \text{V lower in potential than point } b\text{)}$$

EVALUATE: Alternatively, we can go from point b down through the $6.00\ \Omega$ resistor.

$$V_b - I_2(6.00\ \Omega) + I_1(3.00\ \Omega) = V_a$$

$$V_a - V_b = -(4.00\ \text{A})(6.00\ \Omega) + (4.00\ \text{A})(3.00\ \Omega) = -24.0\ \text{V} + 12.0\ \text{V} = -12.0\ \text{V}, \text{ which checks.}$$

(b) IDENTIFY: Now there are multiple current paths, as shown in Figure 26.73b. Use junction rule to write the current in each branch in terms of three unknown currents I_1 , I_2 , and I_3 . Apply the loop rule to three loops to get three equations for the three unknowns. The target variable is I_3 , the current through the switch. R_{eq} is calculated from $V = IR_{\text{eq}}$, where I is the total current that passes through the network.

SET UP:

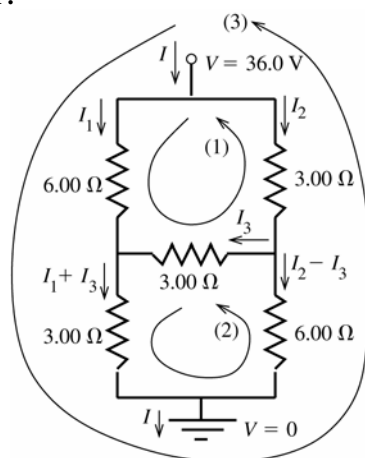

Figure 26.73b

The three unknown currents I_1 , I_2 , and I_3 are labeled on Figure 26.73b.

EXECUTE: Apply the loop rule to loops (1), (2), and (3).

loop (1): $-I_1(6.00\ \Omega) + I_3(3.00\ \Omega) + I_2(3.00\ \Omega) = 0$

$$I_2 = 2I_1 - I_3 \quad \text{eq.(1)}$$

loop (2): $-(I_1 + I_3)(3.00\ \Omega) + (I_2 - I_3)(6.00\ \Omega) - I_3(3.00\ \Omega) = 0$

$$6I_2 - 12I_3 - 3I_1 = 0 \text{ so } 2I_2 - 4I_3 - I_1 = 0$$

Use eq.(1) to replace I_2 :

$$4I_1 - 2I_3 - 4I_3 - I_1 = 0$$

$$3I_1 = 6I_3 \text{ and } I_1 = 2I_3 \quad \text{eq.(2)}$$

loop (3) (This loop is completed through the battery [not shown], in the direction from the $-$ to the $+$ terminal.):

$$-I_1(6.00\ \Omega) - (I_1 + I_3)(3.00\ \Omega) + 36.0\ \text{V} = 0$$

$$9I_1 + 3I_3 = 36.0\ \text{A} \text{ and } 3I_1 + I_3 = 12.0\ \text{A} \quad \text{eq.(3)}$$

Use eq.(2) in eq.(3) to replace I_1 :

$$3(2I_3) + I_3 = 12.0\ \text{A}$$

$$I_3 = 12.0\ \text{A} / 7 = 1.71\ \text{A}$$

$$I_1 = 2I_3 = 3.42\ \text{A}$$

$$I_2 = 2I_1 - I_3 = 2(3.42\ \text{A}) - 1.71\ \text{A} = 5.13\ \text{A}$$

The current through the switch is $I_3 = 1.71\ \text{A}$.

(c) From the results in part (a) the current through the battery is $I = I_1 + I_2 = 3.42 \text{ A} + 5.13 \text{ A} = 8.55 \text{ A}$. The equivalent circuit is a single resistor that produces the same current through the 36.0 V battery, as shown in Figure 26.73c.

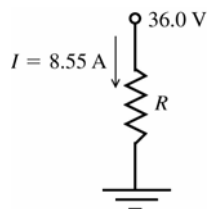

Figure 26.73c

$$-IR + 36.0 \text{ V} = 0$$

$$R = \frac{36.0 \text{ V}}{I} = \frac{36.0 \text{ V}}{8.55 \text{ A}} = 4.21 \Omega$$

EVALUATE: With the switch open (part a), point b is at higher potential than point a , so when the switch is closed the current flows in the direction from b to a . With the switch closed the circuit cannot be simplified using series and parallel combinations but there is still an equivalent resistance that represents the network.

26.74. IDENTIFY: With S open and after equilibrium has been reached, no current flows and the voltage across each capacitor is 18.0 V. When S is closed, current I flows through the 6.00Ω and 3.00Ω resistors.

SET UP: With the switch closed, a and b are at the same potential and the voltage across the 6.00Ω resistor equals the voltage across the $6.00 \mu\text{F}$ capacitor and the voltage is the same across the $3.00 \mu\text{F}$ capacitor and 3.00Ω resistor.

EXECUTE: (a) With an open switch: $V_{ab} = \mathcal{E} = 18.0 \text{ V}$.

(b) Point a is at a higher potential since it is directly connected to the positive terminal of the battery.

(c) When the switch is closed $18.0 \text{ V} = I(6.00 \Omega + 3.00 \Omega)$. $I = 2.00 \text{ A}$ and $V_b = (2.00 \text{ A})(3.00 \Omega) = 6.00 \text{ V}$.

(d) Initially the capacitor's charges were $Q_3 = CV = (3.00 \times 10^{-6} \text{ F})(18.0 \text{ V}) = 5.40 \times 10^{-5} \text{ C}$ and

$Q_6 = CV = (6.00 \times 10^{-6} \text{ F})(18.0 \text{ V}) = 1.08 \times 10^{-4} \text{ C}$. After the switch is closed

$Q_3 = CV = (3.00 \times 10^{-6} \text{ F})(18.0 \text{ V} - 12.0 \text{ V}) = 1.80 \times 10^{-5} \text{ C}$ and

$Q_6 = CV = (6.00 \times 10^{-6} \text{ F})(18.0 \text{ V} - 6.0 \text{ V}) = 7.20 \times 10^{-5} \text{ C}$. Both capacitors lose $3.60 \times 10^{-5} \text{ C}$.

EVALUATE: The voltage across each capacitor decreases when the switch is closed, because there is then current through each resistor and therefore a potential drop across each resistor.

26.75. IDENTIFY: The current through the galvanometer for full-scale deflection is 0.0200 A. For each connection, there are two parallel branches and the voltage across each is the same.

SET UP: The sum of the two currents in the parallel branches for each connection equals the current into the meter for that connection.

EXECUTE: From the circuit we can derive three equations:

(i) $(R_1 + R_2 + R_3)(0.100 \text{ A} - 0.0200 \text{ A}) = (48.0 \Omega)(0.0200 \text{ A})$ and $R_1 + R_2 + R_3 = 12.0 \Omega$.

(ii) $(R_1 + R_2)(1.00 \text{ A} - 0.0200 \text{ A}) = (48.0 \Omega + R_3)(0.0200 \text{ A})$ and $R_1 + R_2 - 0.0204R_3 = 0.980 \Omega$.

(iii) $R_1(10.0 \text{ A} - 0.0200 \text{ A}) = (48.0 \Omega + R_2 + R_3)(0.0200 \text{ A})$ and $R_1 - 0.002R_2 - 0.002R_3 = 0.096 \Omega$.

From (i) and (ii), $R_3 = 10.8 \Omega$. From (ii) and (iii), $R_2 = 1.08 \Omega$. Therefore, $R_1 = 0.12 \Omega$.

EVALUATE: For the 0.100 A setting the circuit consists of 48.0Ω and $R_1 + R_2 + R_3 = 12.0 \Omega$ in parallel and the equivalent resistance of the meter is 9.6Ω . For each of the other two settings the equivalent resistance of the meter is less than 9.6Ω .

26.76. IDENTIFY: In each case the sum of the voltage drops across the resistors in the circuit must equal the full-scale voltage reading. The resistors are in series so the total resistance is the sum of the resistances in the circuit.

SET UP: For each range setting the circuit has the form shown in Figure 26.76.

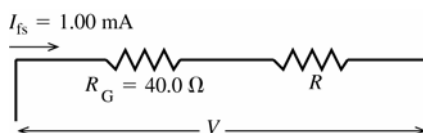

Figure 26.76

EXECUTE: 3.00 V

For $V = 3.00 \text{ V}$, $R = R_1$ and the total meter resistance R_m is $R_m = R_G + R_1$.

$$V = I_{\text{fs}} R_m \text{ so } R_m = \frac{V}{I_{\text{fs}}} = \frac{3.00 \text{ V}}{1.00 \times 10^{-3} \text{ A}} = 3.00 \times 10^3 \Omega.$$

$$R_m = R_G + R_1 \text{ so } R_1 = R_m - R_G = 3.00 \times 10^3 \Omega - 40.0 \Omega = 2960 \Omega$$

15.0 V

For $V = 15.0 \text{ V}$, $R = R_1 + R_2$ and the total meter resistance is $R_m = R_G + R_1 + R_2$.

$$V = I_{fs} R_m \text{ so } R_m = \frac{V}{I_{fs}} = \frac{15.0 \text{ V}}{1.00 \times 10^{-3} \text{ A}} = 1.50 \times 10^4 \Omega.$$

$$R_2 = R_m - R_G - R_1 = 1.50 \times 10^4 \Omega - 40.0 \Omega - 2960 \Omega = 1.20 \times 10^4 \Omega$$

150 V

For $V = 150 \text{ V}$, $R = R_1 + R_2 + R_3$ and the total meter resistance is $R_m = R_G + R_1 + R_2 + R_3$.

$$V = I_{fs} R_m \text{ so } R_m = \frac{V}{I_{fs}} = \frac{150 \text{ V}}{1.00 \times 10^{-3} \text{ A}} = 1.50 \times 10^5 \Omega.$$

$$R_3 = R_m - R_G - R_1 - R_2 = 1.50 \times 10^5 \Omega - 40.0 \Omega - 2960 \Omega - 1.20 \times 10^4 \Omega = 1.35 \times 10^5 \Omega.$$

EVALUATE: The greater the total resistance in series inside the meter the greater the potential difference between the two connections to the meter when the same 1.00 mA current flows through it.

- 26.77. IDENTIFY:** Connecting the voltmeter between point b and ground gives a resistor network and we can solve for the current through each resistor. The voltmeter reading equals the potential drop across the $200 \text{ k}\Omega$ resistor.

SET UP: For resistors in parallel, $\frac{1}{R_{eq}} = \frac{1}{R_1} + \frac{1}{R_2}$. For resistors in series, $R_{eq} = R_1 + R_2$.

EXECUTE: (a) $R_{eq} = 100 \text{ k}\Omega + \left(\frac{1}{200 \text{ k}\Omega} + \frac{1}{50 \text{ k}\Omega} \right)^{-1} = 140 \text{ k}\Omega$. The total current is $I = \frac{0.400 \text{ kV}}{140 \text{ k}\Omega} = 2.86 \times 10^{-3} \text{ A}$.

The voltage across the $200 \text{ k}\Omega$ resistor is $V_{200\text{k}\Omega} = IR = (2.86 \times 10^{-3} \text{ A}) \left(\frac{1}{200 \text{ k}\Omega} + \frac{1}{50 \text{ k}\Omega} \right)^{-1} = 114.4 \text{ V}$.

(b) If $V_R = 5.00 \times 10^6 \Omega$, then we carry out the same calculations as above to find $R_{eq} = 292 \text{ k}\Omega$,

$$I = 1.37 \times 10^{-3} \text{ A} \text{ and } V_{200\text{k}\Omega} = 263 \text{ V}.$$

(c) If $V_R = \infty$, then we find $R_{eq} = 300 \text{ k}\Omega$, $I = 1.33 \times 10^{-3} \text{ A}$ and $V_{200\text{k}\Omega} = 266 \text{ V}$.

EVALUATE: When a voltmeter of finite resistance is connected to a circuit, current flows through the voltmeter and the presence of the voltmeter alters the currents and voltages in the original circuit. The effect of the voltmeter on the circuit decreases as the resistance of the voltmeter increases.

- 26.78. IDENTIFY:** The circuit consists of two resistors in series with 110 V applied across the series combination.

SET UP: The circuit resistance is $30 \text{ k}\Omega + R$. The voltmeter reading of 68 V is the potential across the voltmeter terminals, equal to $I(30 \text{ k}\Omega)$.

EXECUTE: $I = \frac{110 \text{ V}}{(30 \text{ k}\Omega + R)}$. $I(30 \text{ k}\Omega) = 68 \text{ V}$ gives $(68 \text{ V})(30 \text{ k}\Omega + R) = (110 \text{ V})30 \text{ k}\Omega$ and $R = 18.5 \text{ k}\Omega$.

EVALUATE: This is a method for measuring large resistances.

- 26.79. IDENTIFY and SET UP:** Zero current through the galvanometer means the current I_1 through N is also the current through M and the current I_2 through P is the same as the current through X . And it means that points b and c are at the same potential, so $I_1 N = I_2 P$.

EXECUTE: (a) The voltage between points a and d is \mathcal{E} , so $I_1 = \frac{\mathcal{E}}{N+M}$ and $I_2 = \frac{\mathcal{E}}{P+X}$. Using these

expressions in $I_1 N = I_2 P$ gives $\frac{\mathcal{E}}{N+M} N = \frac{\mathcal{E}}{P+X} P$. $N(P+X) = P(N+M)$. $NX = PM$ and $X = MP/N$.

(b) $X = \frac{MP}{N} = \frac{(850.0 \Omega)(33.48 \Omega)}{15.00 \Omega} = 1897 \Omega$

EVALUATE: The measurement of X does not require that we know the value of the emf.

- 26.80. IDENTIFY:** Add resistors in series and parallel with the second galvanometer, so that the equivalent resistance is 65.0Ω and so that for a current of 1.50 mA into the device the current through the galvanometer is $3.60 \mu\text{A}$.

SET UP: In order for the second galvanometer to give the same full-scale deflection and to have the same resistance as the first, we need two additional resistances as shown in Figure 26.80.

EXECUTE: For $3.60 \mu\text{A}$ through R the current through R_1 is 1.496 mA. R and R_1 are in parallel so have equal voltages: $(3.6 \mu\text{A})(38.0 \Omega) = (1.496 \text{ mA})R_1$ and $R_1 = 91.4 \text{ m}\Omega$. And for the total resistance to be 65.0Ω :

$$65.0 \Omega = R_2 + \left(\frac{1}{38.0 \Omega} + \frac{1}{0.0914 \Omega} \right)^{-1} \text{ and } R_2 = 64.9 \Omega.$$

EVALUATE: Adding R_1 in parallel lowers the equivalent resistance so R_2 must be added in series to raise the equivalent resistance to 65.0Ω .

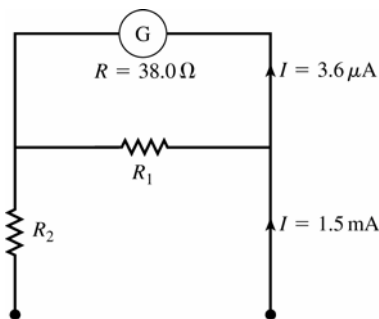

Figure 26.80

26.81. IDENTIFY and SET UP: Without the meter, the circuit consists of the two resistors in series. When the meter is connected, its resistance is added to the circuit in parallel with the resistor it is connected across.

(a) **EXECUTE:** $I = I_1 = I_2$

$$I = \frac{90.0 \text{ V}}{R_1 + R_2} = \frac{90.0 \text{ V}}{224 \Omega + 589 \Omega} = 0.1107 \text{ A}$$

$$V_1 = I_1 R_1 = (0.1107 \text{ A})(224 \Omega) = 24.8 \text{ V}; \quad V_2 = I_2 R_2 = (0.1107 \text{ A})(589 \Omega) = 65.2 \text{ V}$$

(b) **SET UP:** The resistor network is sketched in Figure 26.81a.

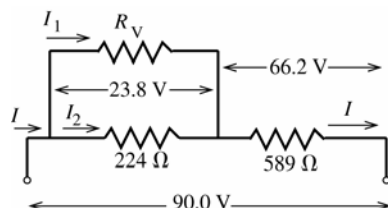

Figure 26.81c

The voltmeter reads the potential difference across its terminals, which is 23.8 V. If we can find the current I_1 through the voltmeter then we can use Ohm's law to find its resistance.

EXECUTE: The voltage drop across the 589Ω resistor is $90.0 \text{ V} - 23.8 \text{ V} = 66.2 \text{ V}$, so

$$I = \frac{V}{R} = \frac{66.2 \text{ V}}{589 \Omega} = 0.1124 \text{ A. The voltage drop across the } 224 \Omega \text{ resistor is } 23.8 \text{ V, so } I_2 = \frac{V}{R} = \frac{23.8 \text{ V}}{224 \Omega} = 0.1062 \text{ A.}$$

Then $I = I_1 + I_2$ gives $I_1 = I - I_2 = 0.1124 \text{ A} - 0.1062 \text{ A} = 0.0062 \text{ A}$. $R_v = \frac{V}{I_1} = \frac{23.8 \text{ V}}{0.0062 \text{ A}} = 3840 \Omega$

(c) **SET UP:** The circuit with the voltmeter connected is sketched in Figure 26.81b.

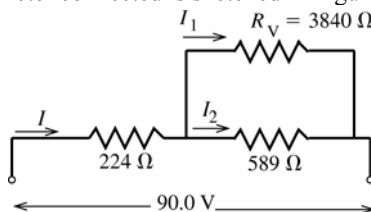

Figure 26.81b

EXECUTE: Replace the two resistors in parallel by their equivalent, as shown in Figure 26.81c.

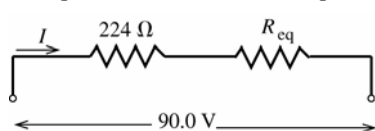

Figure 26.81c

$$\frac{1}{R_{\text{eq}}} = \frac{1}{3840 \Omega} + \frac{1}{589 \Omega};$$

$$R_{\text{eq}} = \frac{(3840 \Omega)(589 \Omega)}{3840 \Omega + 589 \Omega} = 510.7 \Omega$$

$$I = \frac{90.0 \text{ V}}{224 \Omega + 510.7 \Omega} = 0.1225 \text{ A}$$

The potential drop across the 224Ω resistor then is $IR = (0.1225 \text{ A})(224 \Omega) = 27.4 \text{ V}$, so the potential drop across the 589Ω resistor and across the voltmeter (what the voltmeter reads) is $90.0 \text{ V} - 27.4 \text{ V} = 62.6 \text{ V}$.

(d) **EVALUATE:** No, any real voltmeter will draw some current and thereby reduce the current through the resistance whose voltage is being measured. Thus the presence of the voltmeter connected in parallel with the resistance lowers the voltage drop across that resistance. The resistance of the voltmeter is only about a factor of ten larger than the resistances in the circuit, so the voltmeter has a noticeable effect on the circuit.

26.82. IDENTIFY: Just after the connection is made, $q = 0$ and the voltage across the capacitor is zero. After a long time $i = 0$.

SET UP: The rate at which the resistor dissipates electrical energy is $P_R = V^2/R$, where V is the voltage across the resistor. The energy stored in the capacitor is $q^2/2C$. The power output of the source is $P_\epsilon = \mathcal{E}i$.

EXECUTE: (a) (i) $P_R = \frac{V^2}{R} = \frac{(120 \text{ V})^2}{4.26 \Omega} = 3380 \text{ W}$. (ii) $P_C = \frac{dU}{dt} = \frac{1}{2C} \frac{d(q^2)}{dt} = \frac{iq}{C} = 0$.

(iii) $P_\epsilon = \mathcal{E}I = (120 \text{ V}) \frac{120 \text{ V}}{4.26 \Omega} = 3380 \text{ W}$.

(b) After a long time, $i = 0$, so $P_R = 0$, $P_C = 0$, $P_\epsilon = 0$.

EVALUATE: Initially all the power output of the source is dissipated in the resistor. After a long time energy is stored in the capacitor but the amount stored isn't changing.

26.83. IDENTIFY: Apply the loop rule to the circuit. The initial current determines R . We can then use the time constant to calculate C .

SET UP: The circuit is sketched in Figure 26.83.

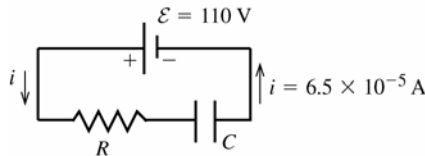

Figure 26.83

Initially, the charge of the capacitor is zero, so by $v = q/C$ the voltage across the capacitor is zero.

EXECUTE: The loop rule therefore gives $\mathcal{E} - iR = 0$ and $R = \frac{\mathcal{E}}{i} = \frac{110 \text{ V}}{6.5 \times 10^{-5} \text{ A}} = 1.7 \times 10^6 \Omega$

The time constant is given by $\tau = RC$ (Eq. 26.14), so $C = \frac{\tau}{R} = \frac{6.2 \text{ s}}{1.7 \times 10^6 \Omega} = 3.6 \mu\text{F}$.

EVALUATE: The resistance is large so the initial current is small and the time constant is large.

26.84. IDENTIFY: The energy stored in a capacitor is $U = q^2/2C$. The electrical power dissipated in the resistor is $P = i^2R$.

SET UP: For a discharging capacitor, $i = -\frac{q}{RC}$.

EXECUTE: (a) $U_0 = \frac{Q_0^2}{2C} = \frac{(0.0081 \text{ C})^2}{2(4.62 \times 10^{-6} \text{ F})} = 7.10 \text{ J}$.

(b) $P_0 = I_0^2 R = \left(\frac{Q_0}{RC}\right)^2 R = \frac{(0.0081 \text{ C})^2}{(850 \Omega)(4.62 \times 10^{-6} \text{ F})^2} = 3616 \text{ W}$

(c) When $U = \frac{1}{2}U_0 = \frac{1}{2} \frac{Q_0^2}{2C}$, $Q = \frac{Q_0}{\sqrt{2}}$. This gives $P = \left(\frac{Q}{RC}\right)^2 R = \frac{1}{2} \left(\frac{Q_0}{RC}\right)^2 R = \frac{1}{2}P_0 = 1808 \text{ W}$.

EVALUATE: All the energy originally stored in the capacitor is dissipated as current flow through the resistor.

26.85. IDENTIFY: $q = Q_0 e^{-t/RC}$. The time constant is $\tau = RC$.

SET UP: The charge of one electron has magnitude $e = 1.60 \times 10^{-19} \text{ C}$.

EXECUTE: (a) We will say that a capacitor is discharged if its charge is less than that of one electron. The time this takes is then given by $q = Q_0 e^{-t/RC}$, so $t = RC \ln(Q_0/e) = (6.7 \times 10^5 \Omega)(9.2 \times 10^{-7} \text{ F}) \ln(7.0 \times 10^{-6} \text{ C}/1.6 \times 10^{-19} \text{ C}) = 19.36 \text{ s}$, or 31.4 time constants.

EVALUATE: (b) As shown in part (a), $t = \tau \ln(Q_0/q)$ and so the number of time constants required to discharge the capacitor is independent of R and C , and depends only on the initial charge.

26.86. IDENTIFY: The energy changes exponentially, but it does not obey exactly the same equation as the charge since it is proportional to the square of the charge.

(a) **SET UP:** For charging, $U = Q^2/2C = (Q_0 e^{-t/RC})^2/2C = U_0 e^{-2t/RC}$.

EXECUTE: To reduce the energy to $1/e$ of its initial value:

$$U_0/e = U_0 e^{-2t/RC}$$

$$t = RC/2$$

(b) SET UP: For discharging, $U = Q^2/2C = [Q_0(1 - e^{-t/RC})]^2/2C = U_{\max}(1 - e^{-t/RC})^2$

EXECUTE: To reach $1/e$ of the maximum energy, $U_{\max}/e = U_{\max}(1 - e^{-t/RC})^2$ and $t = -RC \ln\left(1 - \frac{1}{\sqrt{e}}\right)$.

EVALUATE: The time to reach $1/e$ of the maximum energy is not the same as the time to discharge to $1/e$ of the maximum energy.

26.87. IDENTIFY and SET UP: For parts (a) and (b) evaluate the integrals as specified in the problem. The current as a function of time is given by Eq.(26.13) $i = \frac{\mathcal{E}}{R}e^{-t/RC}$. The energy stored in the capacitor is given by $Q^2/2C$.

EXECUTE: (a) $P = \mathcal{E}i$

The total energy supplied by the battery is $\int_0^\infty P dt = \int_0^\infty \mathcal{E}i dt = (\mathcal{E}^2/R) \int_0^\infty e^{-t/RC} dt = (\mathcal{E}^2/R) [-RCe^{-t/RC}]_0^\infty = C\mathcal{E}^2$.

(b) $P = i^2R$

The total energy dissipated in the resistor is

$$\int_0^\infty P dt = \int_0^\infty i^2 R dt = (\mathcal{E}^2/R) \int_0^\infty e^{-2t/RC} dt = (\mathcal{E}^2/R) [-(RC/2)e^{-2t/RC}]_0^\infty = \frac{1}{2}C\mathcal{E}^2.$$

(c) The final charge on the capacitor is $Q = C\mathcal{E}$. The energy stored is $U = Q^2/(2C) = \frac{1}{2}C\mathcal{E}^2$. The final energy stored in the capacitor ($\frac{1}{2}C\mathcal{E}^2$) = total energy supplied by the battery ($C\mathcal{E}^2$) – energy dissipated in the resistor ($\frac{1}{2}C\mathcal{E}^2$)

(d) EVALUATE: $\frac{1}{2}$ of the energy supplied by the battery is stored in the capacitor. This fraction is independent of R . The other $\frac{1}{2}$ of the energy supplied by the battery is dissipated in the resistor. When R is small the current initially is large but dies away quickly. When R is large the current initially is small but lasts longer.

26.88. IDENTIFY: $E = \int_0^\infty P dt$. The energy stored in a capacitor is $U = q^2/2C$.

SET UP: $i = -\frac{Q_0}{RC}e^{-t/RC}$

EXECUTE: $i = -\frac{Q_0}{RC}e^{-t/RC}$ gives $P = i^2R = \frac{Q_0^2}{RC^2}e^{-2t/RC}$ and $E = \frac{Q_0^2}{RC^2} \int_0^\infty e^{-2t/RC} dt = \frac{Q_0^2}{RC^2} \frac{RC}{2} = \frac{Q_0^2}{2C} = U_0$.

EVALUATE: Increasing the energy stored in the capacitor increases current through the resistor as the capacitor discharges.

26.89. IDENTIFY and SET UP:

EXECUTE: (a) Using Kirchhoff's Rules on the circuit we find:

$$\text{Left loop: } 92 - 140I_1 - 210I_2 + 55 = 0 \Rightarrow 147 - 140I_1 - 210I_2 = 0.$$

$$\text{Right loop: } 57 - 35I_3 - 210I_2 + 55 = 0 \Rightarrow 112 - 210I_2 - 35I_3 = 0.$$

$$\text{Junction rule: } I_1 - I_2 + I_3 = 0.$$

Solving for the three currents we have: $I_1 = 0.300$ A, $I_2 = 0.500$ A, $I_3 = 0.200$ A.

(b) Leaving only the 92-V battery in the circuit:

$$\text{Left loop: } 92 - 140I_1 - 210I_2 = 0. \quad \text{Right loop: } -35I_3 - 210I_2 = 0.$$

Junction rule: $I_1 - I_2 + I_3 = 0$. Solving for the three currents:

$$I_1 = 0.541 \text{ A}, \quad I_2 = 0.077 \text{ A}, \quad I_3 = -0.464 \text{ A}.$$

(c) Leaving only the 57-V battery in the circuit:

$$\text{Left loop: } 140I_1 + 210I_2 = 0. \quad \text{Right loop: } 57 - 35I_3 - 210I_2 = 0.$$

Junction rule: $I_1 - I_2 + I_3 = 0$. Solving for the three currents:

$$I_1 = -0.287 \text{ A}, \quad I_2 = 0.192 \text{ A}, \quad I_3 = 0.480 \text{ A}.$$

(d) Leaving only the 55-V battery in the circuit:

$$\text{Left loop: } 55 - 140I_1 - 210I_2 = 0. \quad \text{Right loop: } 55 - 35I_3 - 210I_2 = 0.$$

Junction rule: $I_1 - I_2 + I_3 = 0$. Solving for the three currents:

$$I_1 = 0.046 \text{ A}, \quad I_2 = 0.231 \text{ A}, \quad I_3 = 0.185 \text{ A}.$$

(e) If we sum the currents from the previous three parts we find:

$$I_1 = 0.300 \text{ A}, \quad I_2 = 0.500 \text{ A}, \quad I_3 = 0.200 \text{ A}, \quad \text{just as in part (a).}$$

(f) Changing the 57-V battery for an 80-V battery just affects the calculation in part (c). It changes to: Left loop: $140I_1 + 210I_2 = 0$. Right loop: $80 - 35I_3 - 210I_2 = 0$.

Junction rule: $I_1 - I_2 + I_3 = 0$. Solving for the three currents:

$$I_1 = -0.403 \text{ A}, \quad I_2 = 0.269 \text{ A}, \quad I_3 = 0.672 \text{ A}.$$

The total current for the full circuit is the sum of (b), (d) and (f) above:

$$I_1 = 0.184 \text{ A}, \quad I_2 = 0.576 \text{ A}, \quad I_3 = 0.392 \text{ A}.$$

EVALUATE: This problem presents an alternative means of solving for currents in multiloop circuits.

26.90. IDENTIFY and SET UP: When C changes after the capacitor is charged, the voltage across the capacitor changes. Current flows through the resistor until the voltage across the capacitor again equals the emf.

EXECUTE: (a) Fully charged: $Q = CV = (10.0 \times 10^{-12} \text{ F})(1000 \text{ V}) = 1.00 \times 10^{-8} \text{ C}$.

(b) The initial current just after the capacitor is charged is $I_0 = \frac{\mathcal{E} - V_{C'}}{R} = \frac{\mathcal{E}}{R} - \frac{q}{RC'}$. This gives $i(t) = \left(\frac{\mathcal{E}}{R} - \frac{q}{RC'} \right) e^{-t/RC'}$,

where $C' = 1.1C$.

(c) We need a resistance such that the current will be greater than $1 \mu\text{A}$ for longer than $200 \mu\text{s}$. This requires that

at $t = 200 \mu\text{s}$, $i = 1.0 \times 10^{-6} \text{ A} = \frac{1}{R} \left(1000 \text{ V} - \frac{1.0 \times 10^{-8} \text{ C}}{1.1(1.0 \times 10^{-11} \text{ F})} \right) e^{-(2.0 \times 10^{-4} \text{ s})/R(1.1 \times 10^{-12} \text{ F})}$. This says

$1.0 \times 10^{-6} \text{ A} = \frac{1}{R} (90.9) e^{-(1.8 \times 10^7 \Omega)/R}$ and $18.3R - R \ln R - 1.8 \times 10^7 = 0$. Solving for R numerically we find

$$7.15 \times 10^6 \Omega \leq R \leq 7.01 \times 10^7 \Omega.$$

EVALUATE: If the resistance is too small, then the capacitor discharges too quickly, and if the resistance is too large, the current is not large enough.

26.91. IDENTIFY: Consider one segment of the network attached to the rest of the network.

SET UP: We can re-draw the circuit as shown in Figure 26.91.

EXECUTE: $R_T = 2R_1 + \left(\frac{1}{R_2} + \frac{1}{R_T} \right)^{-1} = 2R_1 + \frac{R_2 R_T}{R_2 + R_T}$. $R_T^2 - 2R_1 R_T - 2R_1 R_2 = 0$. $R_T = R_1 \pm \sqrt{R_1^2 + 2R_1 R_2}$. $R_T > 0$,

so $R_T = R_1 + \sqrt{R_1^2 + 2R_1 R_2}$.

EVALUATE: Even though there are an infinite number of resistors, the equivalent resistance of the network is finite.

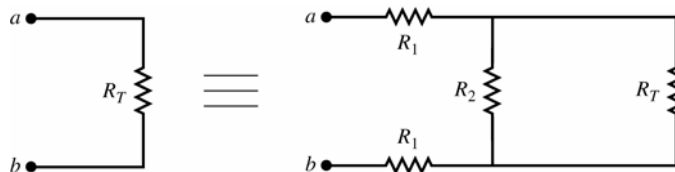

Figure 26.91

26.92. IDENTIFY: Assume a voltage V applied between points a and b and consider the currents that flow along each path between a and b .

SET UP: The currents are shown in Figure 26.92.

EXECUTE: Let current I enter at a and exit at b . At a there are three equivalent branches, so current is $I/3$ in each. At the next junction point there are two equivalent branches so each gets current $I/6$. Then at b there are three equivalent branches with current $I/3$ in each. The voltage drop from a to b then is

$V = \left(\frac{I}{3} \right) R + \left(\frac{I}{6} \right) R + \left(\frac{I}{3} \right) R = \frac{5}{6} IR$. This must be the same as $V = IR_{\text{eq}}$, so $R_{\text{eq}} = \frac{5}{6} R$.

EVALUATE: The equivalent resistance is less than R , even though there are 12 resistors in the network.

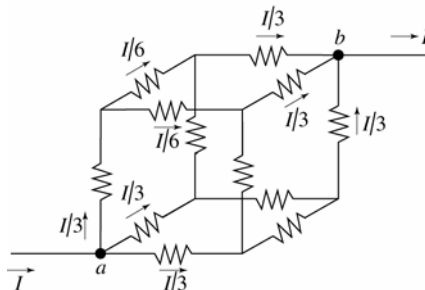

Figure 26.92

26.93. IDENTIFY: The network is the same as the one in Challenge Problem 26.91, and that problem shows that the equivalent resistance of the network is $R_T = \sqrt{R_1^2 + 2R_1R_2}$.

SET UP: The circuit can be redrawn as shown in Figure 26.93.

EXECUTE: (a) $V_{cd} = V_{ab} \frac{R_{\text{eq}}}{2R_1 + R_{\text{eq}}} = V_{ab} \frac{1}{2R_1/R_{\text{eq}} + 1}$ and $R_{\text{eq}} = \frac{R_2R_T}{R_2 + R_T}$. But $\beta = \frac{2R_1(R_T + R_2)}{R_T R_2} = \frac{2R_1}{R_{\text{eq}}}$, so

$$V_{cd} = V_{ab} \frac{1}{1 + \beta}.$$

$$(b) V_1 = \frac{V_0}{(1 + \beta)} \Rightarrow V_2 = \frac{V_1}{(1 + \beta)} = \frac{V_0}{(1 + \beta)^2} \Rightarrow V_n = \frac{V_{n-1}}{(1 + \beta)} = \frac{V_0}{(1 + \beta)^n}.$$

If $R_1 = R_2$, then $R_T = R_1 + \sqrt{R_1^2 + 2R_1R_1} = R_1(1 + \sqrt{3})$ and $\beta = \frac{2(2 + \sqrt{3})}{1 + \sqrt{3}} = 2.73$. So, for the n th segment to have 1%

of the original voltage, we need: $\frac{1}{(1 + \beta)^n} = \frac{1}{(1 + 2.73)^n} \leq 0.01$. This says $n = 4$, and then $V_4 = 0.005V_0$.

(c) $R_T = R_1 + \sqrt{R_1^2 + 2R_1R_2}$ gives $R_T = 6400 \Omega + \sqrt{(6400 \Omega)^2 + 2(6400 \Omega)(8.0 \times 10^8 \Omega)} = 3.2 \times 10^6 \Omega$ and $\beta = \frac{2(6400 \Omega)(3.2 \times 10^6 \Omega + 8.0 \times 10^8 \Omega)}{(3.2 \times 10^6 \Omega)(8.0 \times 10^8 \Omega)} = 4.0 \times 10^{-3}$.

(d) Along a length of 2.0 mm of axon, there are 2000 segments each 1.0 μm long. The voltage therefore

attenuates by $V_{2000} = \frac{V_0}{(1 + \beta)^{2000}}$, so $\frac{V_{2000}}{V_0} = \frac{1}{(1 + 4.0 \times 10^{-3})^{2000}} = 3.4 \times 10^{-4}$.

(e) If $R_2 = 3.3 \times 10^{12} \Omega$, then $R_T = 2.1 \times 10^8 \Omega$ and $\beta = 6.2 \times 10^{-5}$. This gives

$$\frac{V_{2000}}{V_0} = \frac{1}{(1 + 6.2 \times 10^{-5})^{2000}} = 0.88.$$

EVALUATE: As R_2 increases, β decreases and the potential difference decrease from one section to the next is less.

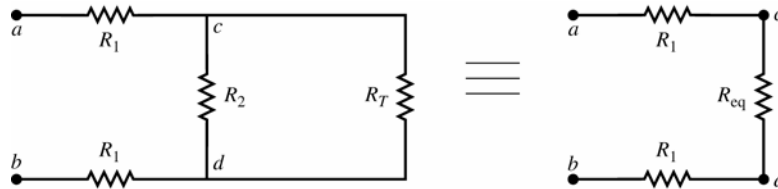

Figure 26.93